

DMX10V User Guide

Description



ELM Video
Technology, Inc.

pg 1 of 2

The DMX10V is a DMX to 10 Volt Converter / Switch / Solid State Relay Driver. The 1st output is assigned to a specific DMX channel (the remaining channels are assigned consecutively) and will vary in respect in respect to the DMX channels' level from 0 to 10V.

In the **VARIABLE MODE** the output voltage will vary in respect to the DMX level of the assigned channel For example if the DMX start channel is assigned to 10, and the level on channel 10 is 127, then the 1st output will be +5 volts, 0 = 0 volts, 255 = 10 volts etc. Each output will source 20mA. Useful for several applications including converting 10V dimmers (insure your dimmers work within these specifications).

In the **SWITCH MODE** the output voltage will either be full ON or full OFF (0V or 10V), useful for driving Solid State Relays (SSR) for example. The Switch output function has a threshold of 50% that will cause the outputs to either be fully on or off. To eliminate unwanted changes at the 50% level, a padded value has been implemented. To turn ON the respective output, the DMX level must be 131 or above, to turn OFF, the level must drop to 125 or below. *In the stand alone Pot mode insure the potentiometer is either fully clockwise or fully counterclockwise to prevent intermittent or unwanted changes*

The **External Potentiometer** option allows the user to install a 10K ohm potentiometer to vary the outputs in a stand alone mode and connects to the PCB as shown.

DMX512 Input connects to the pins shown above from the DMX512 input XLR connector pins 2 and 3 respectively. Short the jumper if a looping XLR connector is not installed

Stand Alone Mode – If a DMX signal is not present the Stand Alone Mode is active. The outputs can be set to be OFF or Variable via the potentiometer.

Dip Switches

Dip Switch's 1~9: sets the DMX512 Channels Assignments (*see the DMX512 Channel Assignment Document*).

Dip Switch 10: sets the output Mode for all 16 outputs - OFF (down position) = VARIABLE MODE – the outputs vary with the respective DMX levels, ON (up position) = SWITCH MODE - outputs either ON or OFF set by the threshold values mentioned above.

DIP Switch 11: OFF (down position) = In the Stand Alone Mode all of the outputs will be OFF, ON (up position) = In the Stand Alone Mode all of the outputs will vary in respect to the external potentiometer

DIP Switch 12: OFF (down position) = Normal Operation, ON (up position) = Hardware Initialization Mode.

When installing or uninstalling a sub module, repower with this switch ON and the yellow LED will flash. Turn OFF and repower. This will activate or deactivate the specific modules. This sets the internal software settings for the attached hardware.

LED Indicators - LED's to indicate the status of the DMX10V. The power LED will illuminate indicating power is applied.

DATA LED: ON = indicates DMX data is being received.
OFF = indicates no DMX data is being received and the unit is in Stand Alone Mode
SLOW BLINK = DMX receive error – [overrun error] (reset clears)
FAST BLINK = Communications error(s) with the output circuits (reset clears).

If error continues reinitialize the hardware with the instructions above

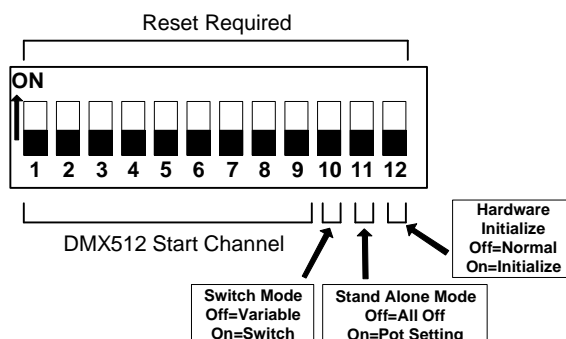

DMX10V User Guide

PCB Connections



**ELM Video
Technology, Inc.**

pg 2 of 2

Top View

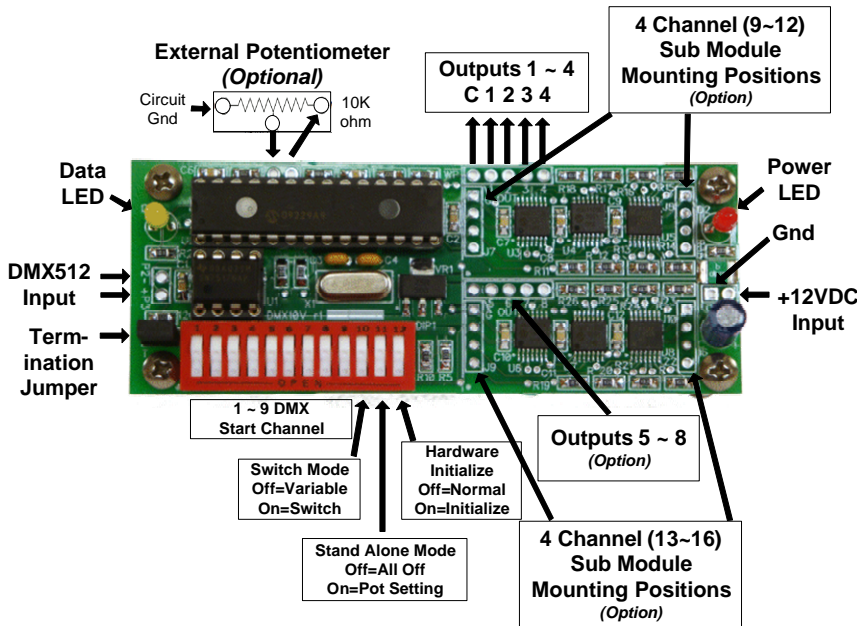

WARNING!
Damage will result if REVERSE VOLTAGE is applied to the input voltage terminals. Take great care that the +12V and Gnd connections are connected as marked on the PCB

Back View

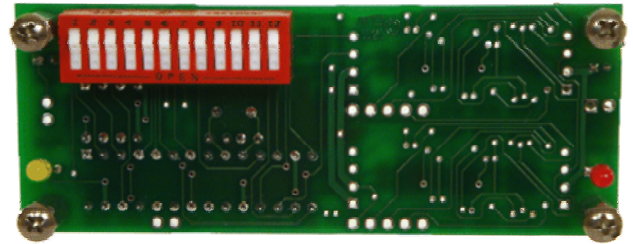

Alternative DIP Switch and LED Mounting

The Alternate back mounting option allows the PCB to be mounted in an enclosure with DIP and LED's access able external of the enclosure. For installations that need top DIP Switch and LED access ability then these items can be mounted on the top of the PCB.

To install the LED's and DIP switch, decide which side (front or back) of the PCB to mount the components back. If the PCB will be mounted inside an enclosure that only needs access internally then mount the components on the top. If the installation requires seeing the LED's and access to the DIP switch's are needed then mount the components on the back. Once the holes are made in the enclosure mount the PCB and wire as shown in the "DMX10V Drill Template and Wiring Diagram" Document.

DMX10V Sub PCB

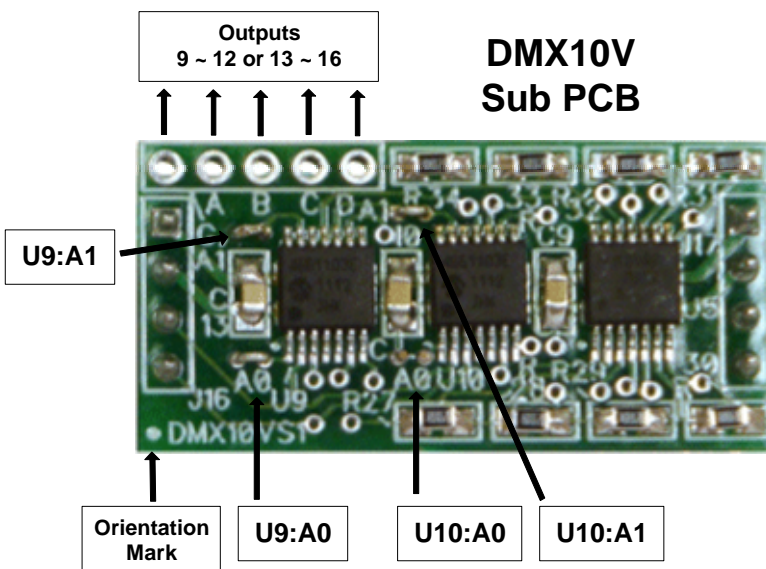

Address Settings: 9 ~ 12
 U9 A0 = Short
 U9 A1 = Short
 U10 A0 = Open
 U10 A1 = Short

Address Settings: 13 ~ 16
 U9 A0 = Short
 U9 A1 = Open
 U10 A0 = Open
 U10 A1 = Open