

DPM-RD PCB Assembly Options

ELM Video Technology, Inc.

DMP4 control board and the DPM-RD regulator driver board. Generates 4 PWM (pulse width modulation/dimmer) or Switch outputs from (user selected) 4 consecutive DMX512 channels.

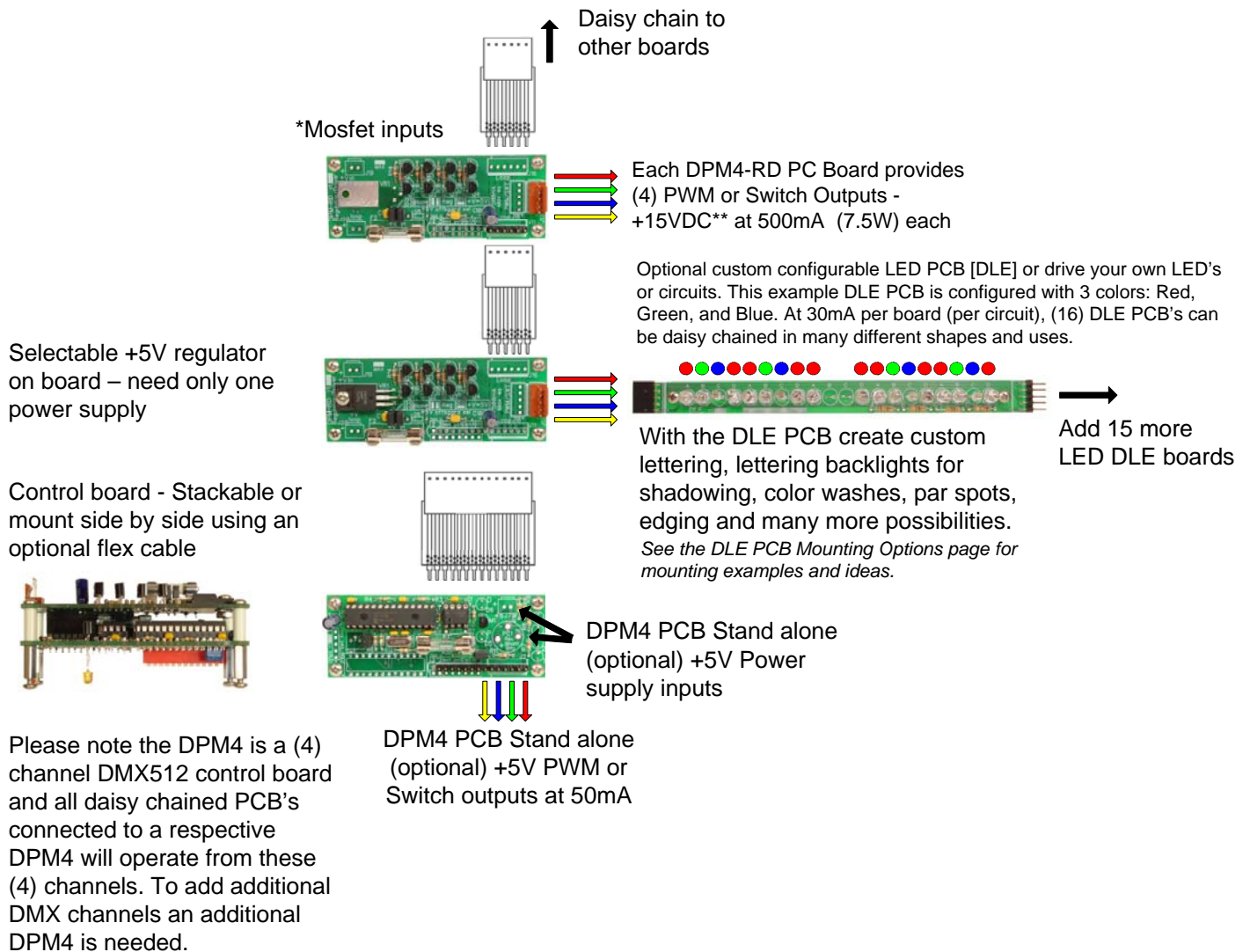

**voltage driven input, not current driven*

***could use lower voltage power supply, depending on the output needs*