

# DSI-4

## DMX Optically Isolated 1x4 Splitter

D Series



---

ELM V.T. Inc.



*(5 pin shown, 3 pin optional)*

**Table Of Contents**

IMPORTANT SAFEGUARDS .....	2
DSI-4 OVERVIEW .....	3
CONNECTION .....	3
OPERATION .....	4
DSI-4 CONFIGURATION EXAMPLE .....	4
PCB BLOCK DIAGRAM .....	4
SERVICING .....	5
TROUBLESHOOTING .....	5
SPECIFICATIONS .....	6

## **Important Safeguards**

Read and follow all instructions BEFORE installing or using this product.

Do not attach any product or accessories that the manufacturer does not recommend.

Keep in a well ventilated environment.

Never use or store the unit in places that are:

- Subject to temperature extremes (direct sunlight, in an enclosed vehicle, near a heating duct)
- Wet, damp and humid areas
- Dusty
- Subject to high levels of vibration

Use proper Power Sources. This product should be operated only from the type of power source indicated on the marking label or as is described in this manual.

Route power cord safely. Don't allow twist's, bend the power cord, or place heavy objects on it.

Ground your equipment whenever possible.

Do not attempt to service this product unless noted otherwise.

If the unit stops working for any reason, unplug the power and other connections until repaired.

This unit should be used only with a rack or chassis that is recommended by the manufacturer.

Unplug the device when not in use.

Keep away from small children.

## DSI-4 OVERVIEW

The DSI-4 is a DMX512 1 in 4 out splitter that takes a DMX 512 output of a lighting console or any device that transmits a DMX512 signal and offers protection by optically isolating it from devices on the daisy chain such as higher voltage dimmers, and actively splits the signal giving 4 separate DMX512 outputs. Optically isolated input offers lighting console protection. Field serviceable: socketed IC's for easy replacement, standard IC's available from many electronic parts suppliers, replaceable power supply, standard 5 x 20mm internal fuse. Power LED and 'Active' LED indicating DMX signal is present.

*NOTE - In order to optically isolate the input and offer protection, the DSI-4 requires a 25mA input line load which is 1/2 of a DMX512 daisy chain load. It is recommended this unit be used directly out of the console. Because of this load the input does not conform to the DMX512 specifications but should work with most systems. For more information about DMX512 visit - <http://www.usitt.org/DMX512.aspx>*

*Also Note - The 4 outputs are separately driven and electronically isolated, not optically isolated from each other.*

## CONNECTION

Loop the power cord through the strain relief. Connect the power supply to the power input connector and apply power. Connect a DMX512 source into the input connector (5 or 3 pin) and insure the data LED is illuminated (showing data is present). If there is an optional loop through connector, connect to other devices or terminate with a 120 ohm terminating connector. *Note - the DSI-4 'active' LED intensity may change by the levels and packet sizes of the data on the line and will illuminate without +5VDC power connected, this is normal.* Use any of the outputs to source up to 32 DMX512 devices (depending on the devices and configuration). As with any DMX512 daisy chain, each output must be terminated at the end of each daisy chain. Unused outputs do not have to be terminated.

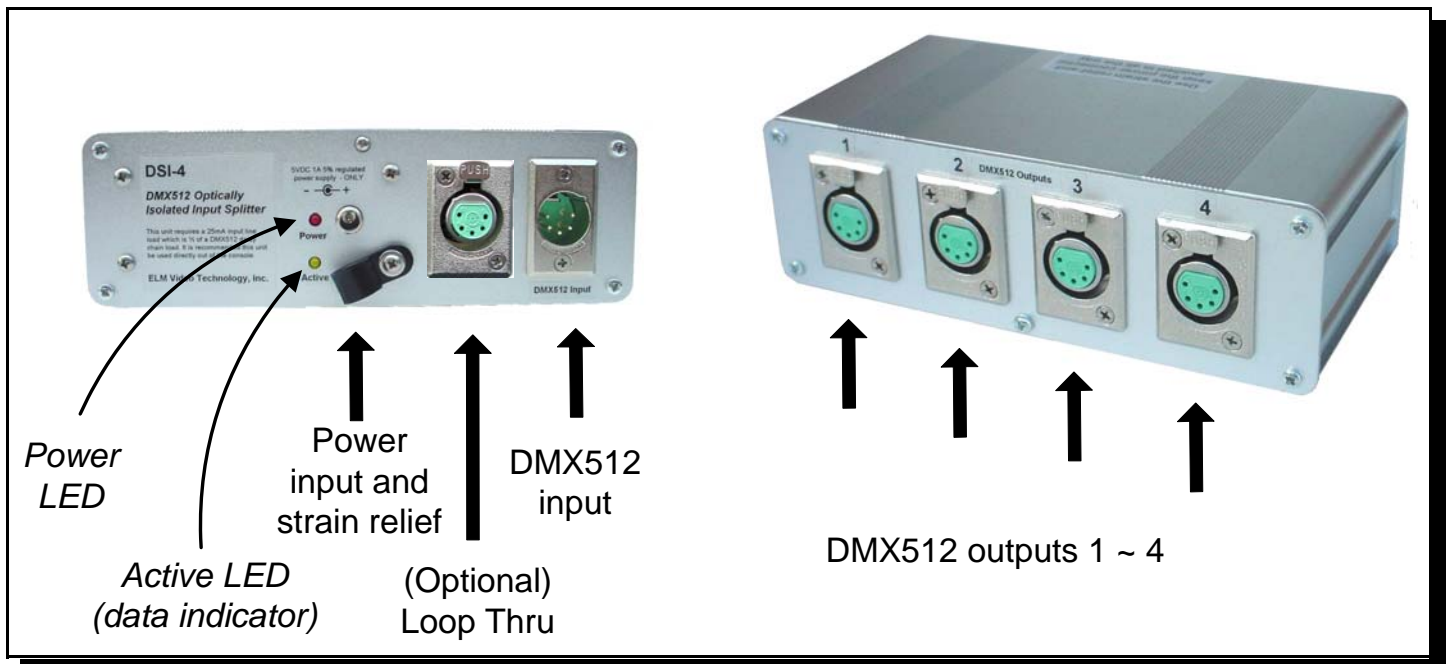

## OPERATION

The DS4 is simple to use. Connect a DMX512 data signal input into the input connector the same DMX512 data signal will be sent out to all 4 outputs independently. Each output can source up to 32 DMX512 devices. There is no user operational controls.

## DSI-4 CONFIGURATION EXAMPLE

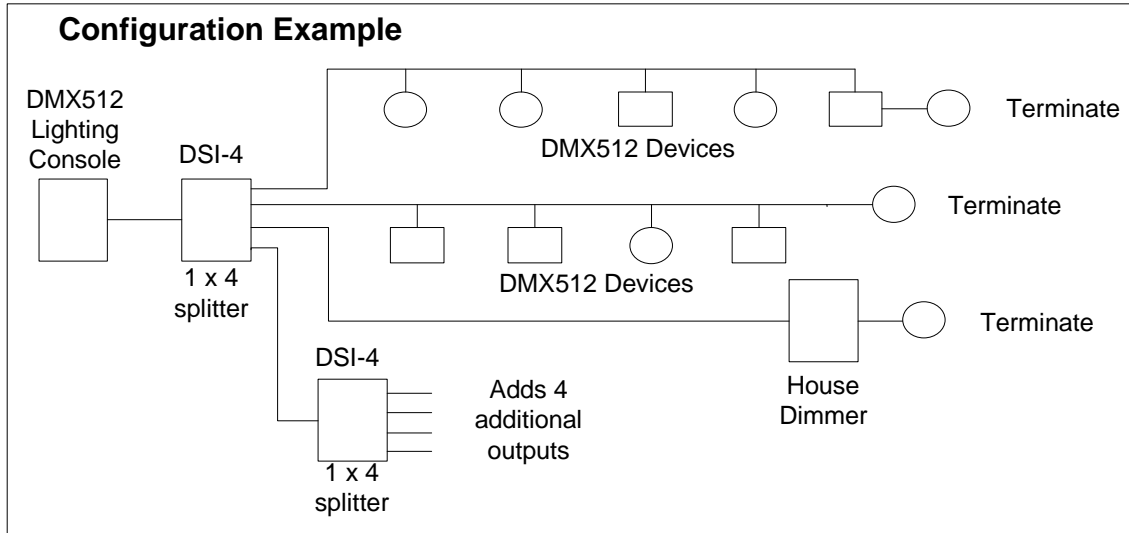

## PCB BLOCK DIAGRAM

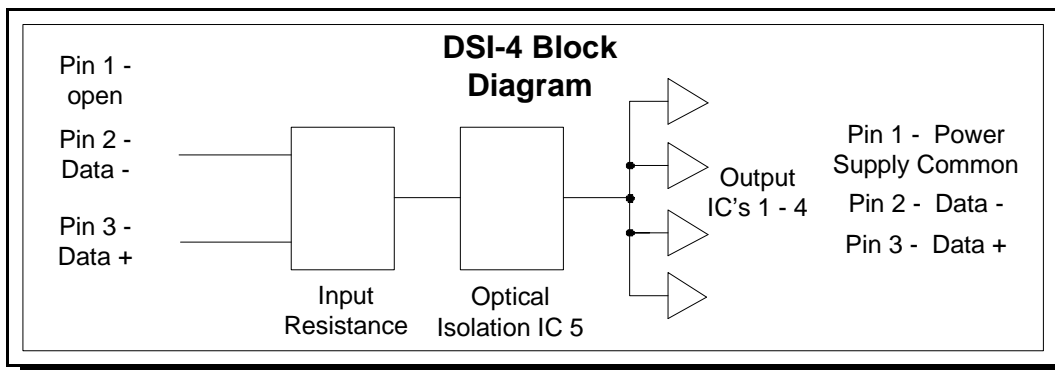

**INPUT:** The input stage has a 68 ohm resistor in series with pin 2 and a 68 ohm resistor in series with pin 3 connecting to the input of IC #5 (*Optically isolated input IC*). There is a 2.2K ohm resistor and the front panel LED (*data indicator LED*) in parallel to the input of IC 5.

**OUTPUT:** The output of IC #5, sources IC #'s 1 ~ 4 that supplies data to the output connectors 1 ~ 4. Pins 1 of each of the output connectors are tied to the power supply common.

for more information about DMX512 visit - <http://www.usitt.org/DMX512.aspx>

## SERVICING

### FIELD SERVICE: For Experienced Technicians

*Note - Take care not to touch the component pins or the inner pins of the connectors. Electrostatic discharge may cause permanent damage to the unit.*

Disconnect all power and data connections. Remove the 5 face plate mounting screws on the PCB side. Use only direct replacement parts and use static discharge precautions.

To replace an IC, using a small flat screwdriver carefully remove the IC by gently lifting up between the socket and the IC keeping the IC as flat as possible. Bend the replacement IC's legs so they are pointing straight down and not angled outward. Align each pin in the center of each pin hole and gently snap into place, all legs at one time, DO NOT insert at an angle. Insure the IC is flush on the socket with all pins.

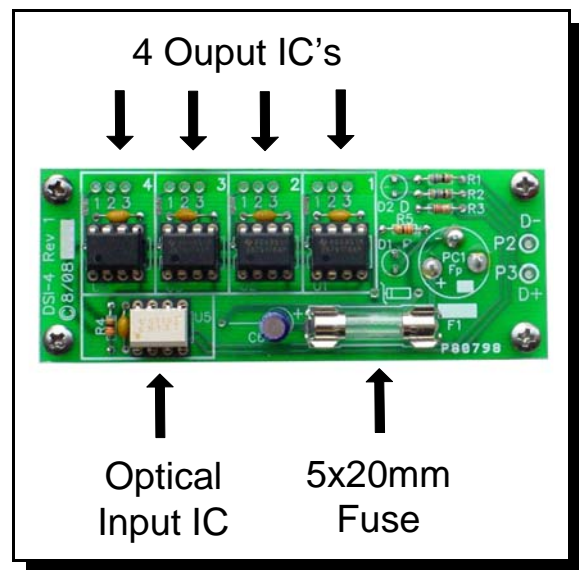
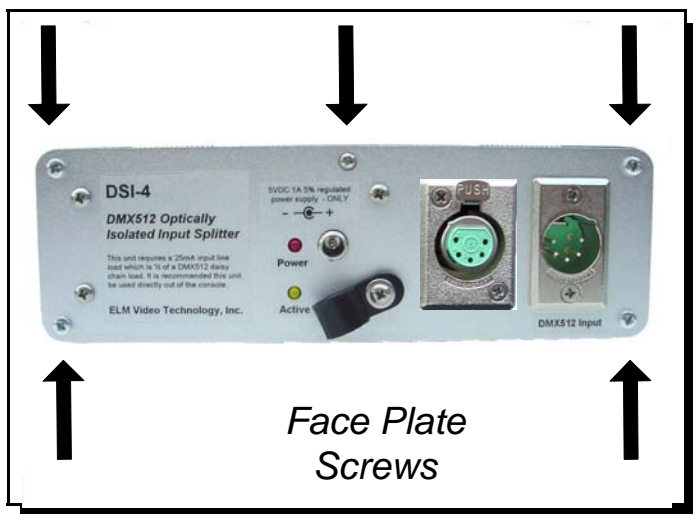

## TROUBLESHOOTING

PROBLEM	CHECK
<ul style="list-style-type: none"> <li>Unit won't power up</li> </ul>	<ul style="list-style-type: none"> <li>check fuse and power connections</li> </ul>
<ul style="list-style-type: none"> <li>If any one of the outputs don't work and the other do</li> </ul>	<ul style="list-style-type: none"> <li>replace the respective output IC (i.e. output doesn't work 4 replace IC # 4).</li> </ul>
<ul style="list-style-type: none"> <li>If all outputs don't work</li> </ul>	<ul style="list-style-type: none"> <li>check if power is present via the power LED, if not check the internal fuse.</li> <li>check if the input has a DMX512 signal by bypassing the DSI-4, if not check the DMX512 console or source.</li> <li>If the data and power are o.k. replace the input IC and possibly the output IC's.</li> </ul>

## SPECIFICATIONS

CHASSIS:	Anodized Aluminum .093" thick RoHS compliant.
POWER INPUT:	+5VDC regulated 5%, 5.5 x 2.1 x 9.5 connector - center positive
FUSE:	.7 ~ 1 Amp Fast Acting 5 X 20 mm
POWER:	Apx .35 Amps with 4 outputs sourcing 32 loads each
DATA TYPE:	DMX512 (250Khz)
DATA INPUT:	DMX512 - 5 (or 3) pin male XLR, <i>Pin 1 - (Shield) Not connected, Pin 2 Data - , Pin 3 Data +, optically isolated from the outputs</i>
DATA OUTPUT:	4 separate DMX512 outputs - 5 (or 3) pin female XLR's, <i>Pin 1 - Power supply common, Pin 2 Data -, Pin 3 Data +</i>
Dimensions:	3.7 x 6.7 x 2.1 inches
Weight:	1.5 pounds