

MLC

Midi Line Converter

M Series Module



ELM Video
Technology, Inc.

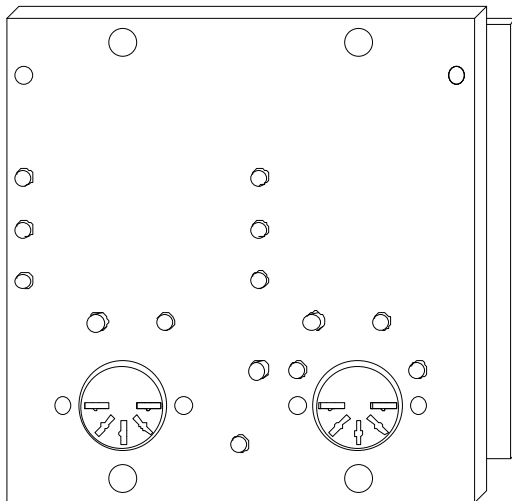

MLC-S
(optional)

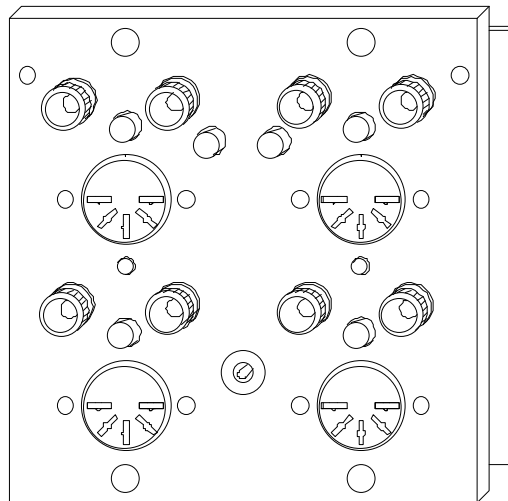

MLC

Table Of Contents

| | |
|------------------------------------|---|
| Important Safeguards | 2 |
| Product Overview | 2 |
| Switch & Connection Overview | 3 |
| Installation | 4 |
| Power and Switch Jumper | 4 |
| Operation | 6 |
| Program Mode Flow Chart | 7 |
| Specifications | 7 |

Important Safeguards

Read and follow all instructions BEFORE installing or using this product.

Do not attach any product or accessories that the manufacturer does not recommend.

Keep in a well ventilated environment.

Never use or store the unit in places that are:

- Subject to temperature extremes (direct sunlight, in an enclosed vehicle, near a heating duct)
- Wet, damp and humid areas
- Dusty
- Subject to high levels of vibration

Use proper Power Sources. This product should be operated only from the type of power source indicated on the marking label or as is described in this manual.

Route power cord safely. Don't allow twist's, bend the power cord, or place heavy objects on it.

Ground your equipment whenever possible.

Do not attempt to service this product unless noted otherwise.

If the unit stops working for any reason, unplug the power and other connections until repaired.

This unit should be used only with a rack or chassis that is recommended by the manufacturer.

Unplug the device when not in use.

Keep away from small children.

PRODUCT OVERVIEW

The MLC module is a dual two input two output midi to line or line to midi converter. Conventional midi signals are good for 50 feet. The MLC module will convert the length to 4000 feet and allows looping (daisy chaining) of up to 30 other MLC module inputs. The input is selected by a switch and both outputs will transmit the input data. There are two independent converters built into the a single module. If an optional MLC-S is attached the MLC can be mounted to the back of the chassis and the MLC-S mounted on the front and adds front access inputs, switchable output capability and (chassis) BUS access.

SWITCH & CONNECTION OVERVIEW

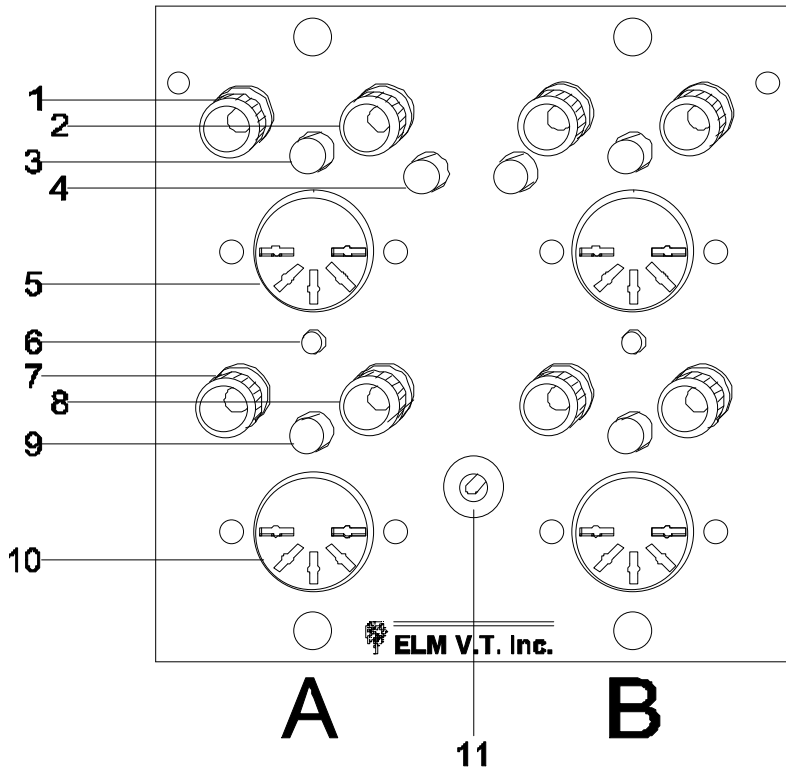

MLC

1. Line Input + Connector
2. Line Input - Connector
3. Line In Termination Switch
4. Input Select Switch
5. Midi Input Connector
6. Selected Data Indicator
7. Line Output + Connector
8. Line Output - Connector
9. Line Out Termination Switch
10. Midi Output Connector
11. +5V Power Input (Optional)

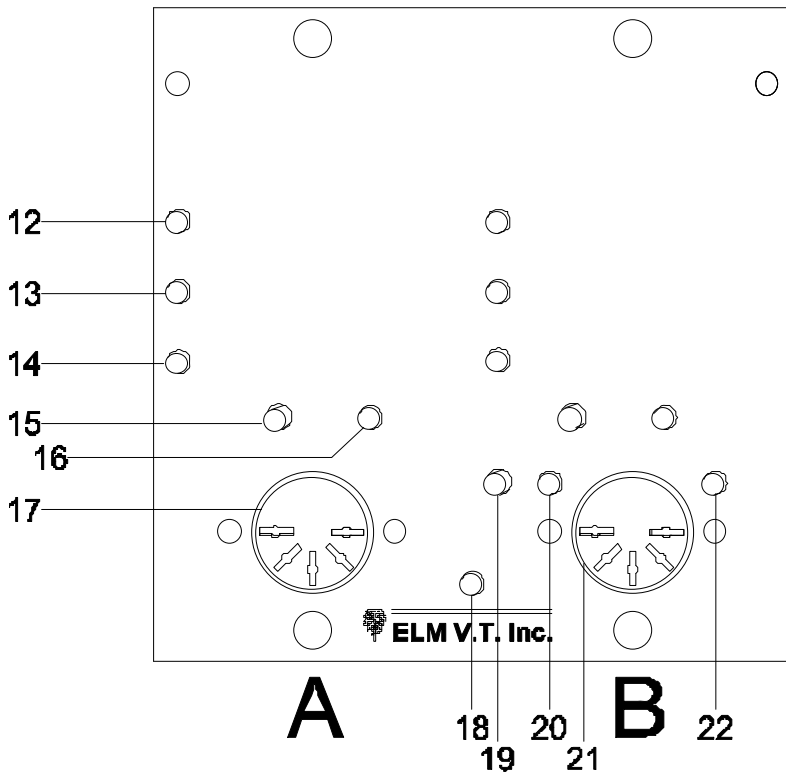

MLC-S (optional)

12. BUS Input Indicator
13. MLC Input Indicator
14. FNT (Front) Input Indicator
15. Input Selection Switch
16. Selected Data Indicator
17. Front Midi Input Connector
18. Module Power Indicator
19. Front Output Selection Switch
20. A Side Output Indicator
21. Front Midi Output Connector
22. B Side Output Indicator

Installation

Note - Take care not to touch the component pins or the inner pins of the connectors. Electrostatic discharge may cause permanent damage to the unit.

Before placing the module into the M Series frame make any necessary jumper changes. If an MLC-S module is used, it will mate with the MLC module on the opposite side of the chassis, take care in mating the 14 pin connector to the MLC.

For each chassis one and ONLY one module should be set up as the 'MAIN' module, all other modules are considered 'SECONDARY' modules. The MAIN module has the power supply connected and supplies the other 4 SECONDARY modules the power via the BUS (ribbon cable) or auxiliary power connector. The MAIN module also can send the received data over the ribbon cable or can be an independent module. Factory jumper settings are not preset and must be properly jumpered to operate.

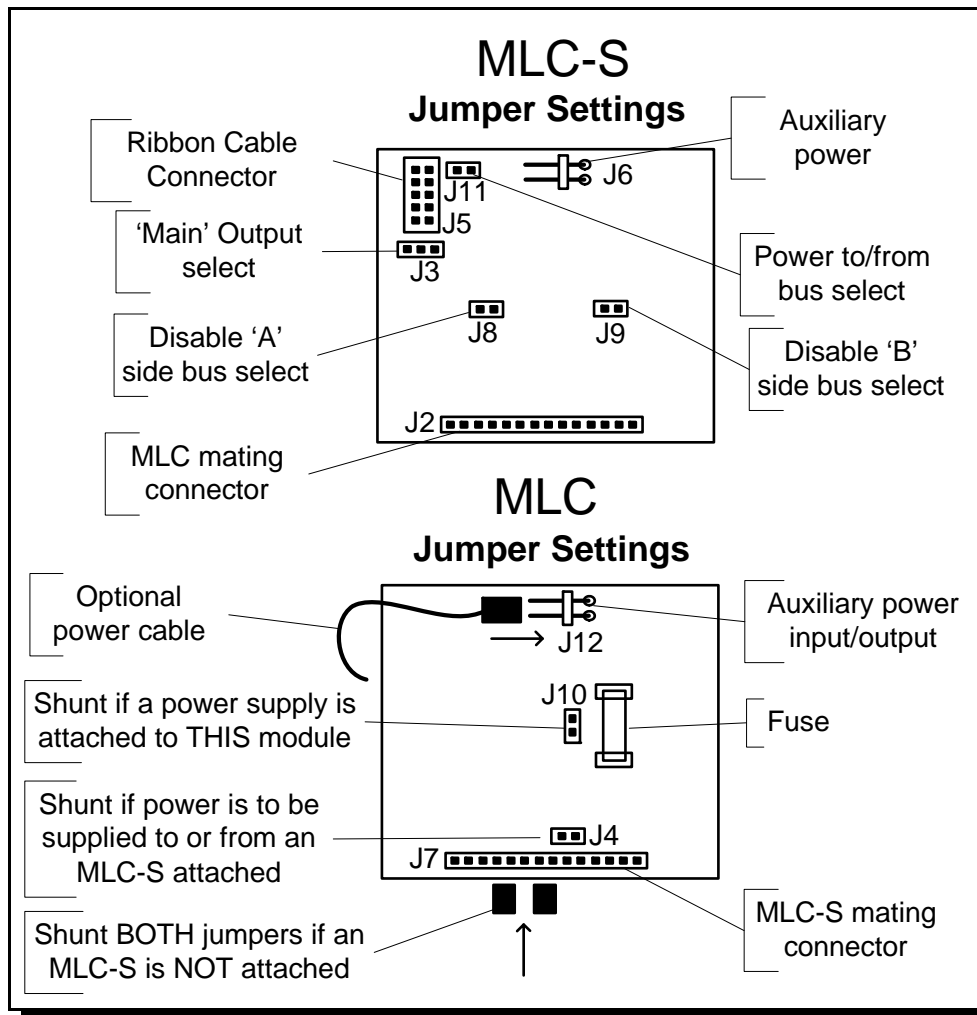

MLC-S POWER JUMPER

SETTINGS - If an MLC-S is used J2 and J7 will mate. J5 is the BUS (Ribbon Cable) connector and if the chassis contains another module with a J5 connector then this connector can be used to supply or send power and data. If power is desired to or from the BUS cable then jumper J11. J6 is an optional +5Vdc input/output.

MLC-S DATA JUMPER SETTINGS

- If this module is the 'MAIN' module and either the 'A' or 'B' side is to SEND data to the other modules in the chassis, then jumper the pins 1 and 2 if the 'A' side is the 'MAIN' or jumper pins 2 and 3 if the 'B' side is the 'MAIN' output. Jumpers J8 and J9 if jumpered will DISABLE the BUS selection. These jumpers should NOT be jumpered unless the respective side is jumpered as the 'MAIN' output via J3.

MLC POWER JUMPER SETTINGS

- If this MLC module has a power supply connected then install a jumper at J10. If this module is to supply power to the MLC-S module (via J7 mating) then install a jumper at J4. If an MLC-S is attached and

power is coming from the BUS (Ribbon Cable) on the MLC-S then jumper J4 and remove J10. J12 is an optional power input/output connector and can be attached to/from other MLC modules via an optional power cable instead of a ribbon cable. If a chassis only contains MLC modules then J12 would allow all 5 modules to use a single power supply.

NOTE ** never allow 2 power supplies to operate in parallel.

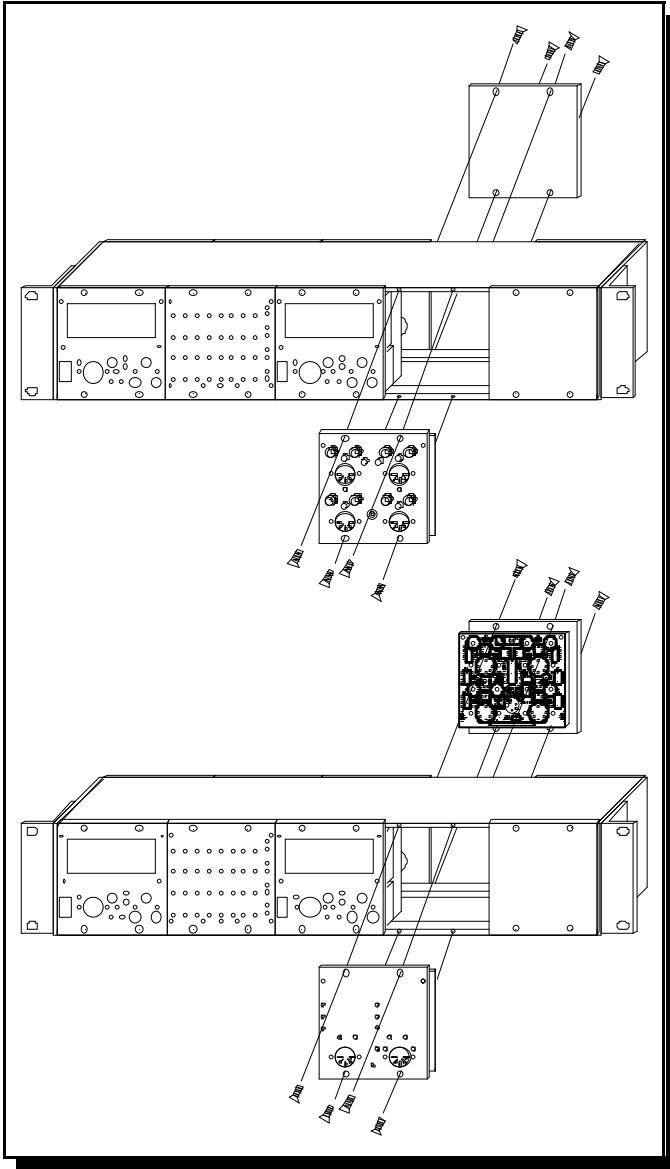

The MLC-S and MLC modules can be installed in any of the 5 module positions using (4) 6-32 screws (supplied with the M series Enclosure). If the module is to be set up as the 'MAIN' module it is recommended to place it in the left most position. Once the jumper settings are set install the modules in the chassis. IF the MLC is to be installed with out an MLC-S mount in one of the spaces and install a blank on the opposite side. If an MLC-S and an MLC is to be installed attach the MLC-S to the front side of the chassis. Install the MLC to the back mating the 14 pin connectors. If more than one module has a BUS (ribbon) connector then attach the ribbon cable (supplied with the M series Enclosure) to the PCB (s) 10 pin connector (J5), note the polarizing plug faces the edge of the board. Inspect the ribbon cable alignment before powering the modules. Install the rear module using (4) 6-32 screws (supplied with the M series Enclosure).

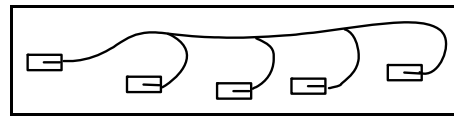

2 conductor power cable

Never use any modified or other modules other than genuine ELM V.T. Inc. modules.

Never allow 2 power supplies to run in parallel or 2 'Data Outputs' (J3) to be connected at the same time within a chassis.

Troubleshooting

| PROBLEM | CHECK |
|--|---|
| <ul style="list-style-type: none"> Unit won't power up | <ul style="list-style-type: none"> check fuse and power connections check the ribbon cable |
| <ul style="list-style-type: none"> Won't receive data on local module | <ul style="list-style-type: none"> verify data is being sent from source check that the ribbon cable is connected properly |
| <ul style="list-style-type: none"> MAIN module will receive data but the SECONDARY modules do not | <ul style="list-style-type: none"> check that J3 is jumpered on MAIN module check that the ribbon cable is connected properly make sure that two data signals are not on the ribbon cable (see jumper settings section) |
| <ul style="list-style-type: none"> Can't select the 'BUS' input on the MLC-S module | <ul style="list-style-type: none"> check that J8 (A side) or J9 (B side) are not jumpered |
| <ul style="list-style-type: none"> Can't select the MLC or 'BCK' input on the MLC-S module | <ul style="list-style-type: none"> check that the MLC 14 pin connections are seated properly |
| <ul style="list-style-type: none"> The receiving MLC modules in the daisy chain don't seem to be receiving data | <ul style="list-style-type: none"> Check the polarity of the wire (green post to green) Insure only ONE MLC module is the OUTPUT and all the other modules are connected to the INPUT Insure there are NOT any 'Y' or split wire configurations in the wiring scheme Insure there are no other connections to the transmit pair |
| | |

Specifications

Power Consumption MLC 130mA

MLC & MLC-S 200mA

Power Input +5 volts DC

Input Power Connector 2.1 mm I.D. X 5.5 mm O.D.

Fuse 2.5 Amp Fast Acting 5 X 20 mm

Dimensions 3.385" wide X 3.485" length

Data Type MIDI 31.5 Khz

Midi Input input 1 (rear) 5 pin female DIN

Midi Output output 1 (rear) 5 pin female DIN, 20 ma output max

Line Input 2 wire (balanced), Binding Post

Line Output 2 wire (balanced), 4000 feet, 32 daisy chain loops, Binding Post

Memory Storage Cycles 10,000 times for each of input A, input B or output selection change

SV 01.11 MR 1