

# DMSC

## *DMX Multi Station Switch Controller User Guide*

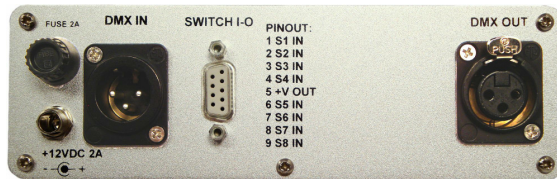

**Desktop**



**DIN / Wall Mount (20 terminal)**



*Stock photo*

1	2	3	4	5	6	7	8	9	10
COM	+12V	DMX	DMX	Shield	DMX	DMX			
GND	IN	IN -	IN +		OUT -	OUT +			
DMX Switch Controller					PWR	DMX	PGM		
ELM Video Technology <small>www.elmvideotechnology.com</small>					S1	S2			
					S3	S4			
Switch	Switch	Switch	Switch	+V	Switch	Switch	Switch	Switch	
1 IN	2 IN	3 IN	4 IN	OUT	5 IN	6 IN	7 IN	8 IN	
11	12	13	14	15	16	17	18	19	20

*Other enclosures may be available, such as 1U, and 2U modular.*

## DMSC OVERVIEW

The DMSC is a DMX multi switch (station or panel) controller that stores DMX scenes and allows them to be recalled with mechanical switches of any type: 2 way, 3 way, 4 way, or toggle switches. The DMSC has 1 DMX input and 1 DMX output, 4 switch inputs. Each switch represents a pre stored static scene and will turn on or off the output levels of the respective scene. The DMSC scenes can easily be recorded from the front accessible PGM button(s). Parameter settings and options are setup by PCB dip switches, see the [PCB Dip Switch Settings] page. A DMX status LED is used to indicate valid DMX (full on), DMX error (1x blink continues until reset), RDM or non zero start code (2x blink/flash). *Note: The DMSC indicates RDM data but does not pass or receive RDM data. See the LED Blink Rate Chart for blink definitions.*

- Store up to 4 static scenes and recall with the flip of a switch from anywhere and multiple locations
- Recall scenes by any style switch such as: 2 way, 3 way, 4 way, or toggle
- OVERRIDE or MERGE the input DMX with the switches (If DMX is present on the input the switches/scenes are optionally overridden and ignored)
- Pre stored scenes merge/combine via HTP (Highest Takes Precedence)
- Optional 5 second transition (fade) times
- Optional DMX Loss Directive, either transition to the switch/scene(s) or shut off
- Optional - Input Switch 4 as a DMX Input disable switch
- Easy set up with internal dip switches

Each preset scene can be HTP (Highest Takes Precedence) merged with other scenes and optionally merged with the incoming DMX input (if applicable). With custom designs each DMSC DMX output can be merged with other DMSC units or other DMX Merger units to offer custom and flexible output options.

## CONNECTION







Optionally connect a DMX source into the input connector (5 or 3 pin). If there is a DMX loop thru connector insure that it is properly terminated locally or at the end of the daisy chain. (If there is not a loop thru connector the unit is internally terminated). The DMX output connector will source up to 32 DMX devices (*depending on the devices and configuration*). Connect the switch wiring as indicated by the legend on the back of the unit and the configuration examples. For the switch selection any type 12VDC or higher rated switch may be used. **DO NOT CONNECT 120VAC TO THE INPUT OF THIS UNIT.** The 12VDC source is provided on pin 5. Solder/connect the switch return wire(s) 1 to pin 1, switch 2 to pin 2, switch 3 to pin 3 and switch 4 to pin 4 as applicable for your unit and installation. If you have an 8 input or higher unit also connect the switch return wire(s) 5 ~ 8 also etc. Check for shorts and wiring errors before powering the unit. Mate the DB9 connector(s) and test operation. For more connection information of the DMSC, see the **DMSC Connection Examples**.

DB9 PINOUT	
Pin	CONNECTION
1	Switch 1 IN
2	Switch 2 IN
3	Switch 3 IN
4	Switch 4 IN
5	+ Volt OUT
6	Switch 5 IN
7	Switch 6 IN
8	Switch 7 IN
9	Switch 8 IN

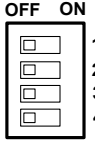
## PCB DIP SWITCH SETTINGS

Set the dip switches for the desired operation and **RESET POWER** to activate the new settings.

To access the dip switches, remove the front cover if applicable (silver box - remove the 5 outer screws, DIN box - remove the 4 silver outer screws, 2 RU module - remove the respective module by removing the 4 black outer screws, 1 RU enclosure - remove the enclosure from the rack and on the rear remove the two plastic retaining clips and slide off the top cover).

	<p><b>D.S. 1 ~ 4: SWITCH / SCENE DISABLE</b> - Disable or enable respective switch/scenes and up.</p> <p>Dip Switch 1 ON - Disable Switch/Scenes 1, 2, 3, and 4 (ignore dip switches 2, 3 and 4)            Dip Switch 2 ON - Disable Switch/Scenes 2, 3, and 4 (ignore dip switches 3 and 4)            Dip Switch 3 ON - Disable Switch/Scenes 3 and 4 (ignore dip switch 4)            Dip Switch 4 ON - Disable Switch/Scene 4</p> <p>All OFF = All switch / scenes are enabled</p>
	<p><b>D.S. 5: - TRANSITION / FADE RATE</b> - Sets the transition rate for switch/scene setting changes. If a respective scene/switch is turned on or off the scene recall will either be immediate or have a 5 second transition rate.</p> <p>Dip Switch 5 OFF - Transition/fade rate = 5 SECONDS            Dip Switch 5 ON - Transition/fade rate = IMMEDIATE</p>
	<p><b>D.S. 6: - DMX LOSS DIRECTIVE</b> - If DMX is lost or no DMX is present on the input this setting determines the output of the DMX output of the DMSC unit. <i>NOTE If ON then Dip Switch 7 must be ON or the switches and scenes are disabled.</i></p> <p>Dip Switch 6 OFF - Transition/fade to switch/scene(s)            Dip Switch 6 ON - DMX output is turned off</p>
	<p><b>D.S. 7: - OVERRIDE SCENE(s) or MERGE/COMBINE with DMX INPUT</b> - IF DIP SWITCH 7 IS OFF = [OVERRIDE] setting, all enabled scene(s) will only be active IF there is not a DMX input signal present, either turning off the DMX lighting board or disconnecting or unplugging the DMX input. IF DIP SWITCH 7 IS ON = [MERGE] - The merge/combine setting will merge/combine all enabled scene(s) with incoming DMX. <i>NOTE Dip Switch 6 must be OFF for this setting to be active.</i></p> <p>Dip Switch 7 OFF - DMX Input will OVERRIDE all switches            Dip Switch 7 ON - DMX will MERGE with enabled switches</p>
	<p><b>D.S. 8: - SLIDER/POT (POTENTIOMETER) AUTO STABILIZE</b> - This setting is for pot/slider units and does not apply for 'Switch' equipped units. This setting will activate the auto stabilize routine preventing small variations in the DMX levels typical with analog potentiometers. DMX level changes of +/- 2 are ignored. Useful if small changes aren't desired.</p> <p>Dip Switch 8 OFF - AUTO STABILIZE is OFF            Dip Switch 8 ON - AUTO STABILIZE is ON</p>
	<p><b>D.S. 9: - SWITCH 4 - DMX INPUT DISABLE</b> - Changes the operation of SWITCH 4 to a DMX input disable switch.</p> <p>If DIP SWITCH 9 is OFF: Input Switch 4 is a standard scene recall switch.</p> <p>If DIP SWITCH 9 is ON: Input Switch 4 acts as a DMX input disable switch. If Input Switch 4 is off Input Switches 1-3 operate normally. If Input Switch 4 is on any DMX input is ignored allowing Input Switches 1-3 to operate regardless if DMX is present. e.g. If activated/desired, input Switch 4 could be located near the lighting control area to control wall switch activation.</p> <p>Dip Switch 9 OFF - Input Switch 4 is a standard scene switch (DMX will operate as normal)            Dip Switch 9 ON - Input Switch 4 re-purposed for DMX Input Disable            Input Switch 4 OFF: with valid DMX Input Switches 1-3 respond in normal operation            Input Switch 4 ON: DMX Input is disabled/ignored, Input Switches 1-3 operate regardless if DMX is present.</p>
<p><b>Dip Switch 10 is not used</b></p>	

Plan all DMX changes carefully, understand how each mode will respond, and thoroughly test each device after any configuration changes. To abort any settings while in the programming mode, toggle the power to reset the unit, or wait 30 seconds for auto abort.

## LED BLINK RATES

DMX LED		SCENE LED'S	
Rate	Description	Rate	Description
OFF	No DMX is being received	OFF	Respective Switch/Scene is Off
ON	Valid DMX is being received	ON	Respective Switch/Scene is On / Active
1x	DMX Input data overrun error has occurred since last powered or DMX connection	1x	Respective scene is selected
2x Flash	RDM data detected	2x	Respective scene is ready to record
2x Blink	Record scene mode attempting to be entered without a DMX input present	2 Flashes	Respective scene has been recorded
		3 Second ON Flicker	Respective scene/switch is on but overridden
		3 Second OFF Flicker	Respective scene/switch is on and the respective scene setting is disabled (DIP switch 6 and/or 7)

## SCENE RECORDING

*NOTE: If Dip Switch 7 (Merge) is on, upon entering the PGM Scene Recording mode, all switch settings will be turned off while programming and will resume upon exiting. To prevent a blackout, preset a DMX scene before entering the PGM Scene Record mode.*

1. Insure a valid DMX signal is present indicated by the DMX input LED on.
2. Preset a desired look from the DMX lighting board or DMX generating device.
3. Enter the PGM Scene Record Mode: Press and hold the PGM button for 3 seconds, the 1st scene will be selected and will blink at a 1x rate. *(NOTE: If Dip Switch 7 [DMX/Switch Merge] is ON - Switches will be temporarily disabled and turned off while in the PGM Scene Record Mode.)*
4. Select the desired scene to record by tapping the PGM button until the desired scene LED is blinking, (to exit the record scene mode tap 4 times).
5. Press and hold the PGM button 3 seconds to confirm selection, the scene LED will blink at the 2x rate. (To exit the scene record mode tap the PGM button.)
6. Insure the scene (seen in real time) is the desired 'look' to be recorded, make any changes from the DMX lighting board or DMX generating device.
7. Press and hold the PGM button for 3 seconds to record the scene. Two flashes on the respective LED will indicate confirmation of the record. *To abort storing, tap the button for 1 second and release.*

Repeat steps to record each scene.

*While in the scene record mode inactivity for 30 seconds will automatically cancel and exit.*

## CONNECTION EXAMPLES

Store and recall up to 8 static scenes with any type switch or standard 2, 3, or 4 way switches

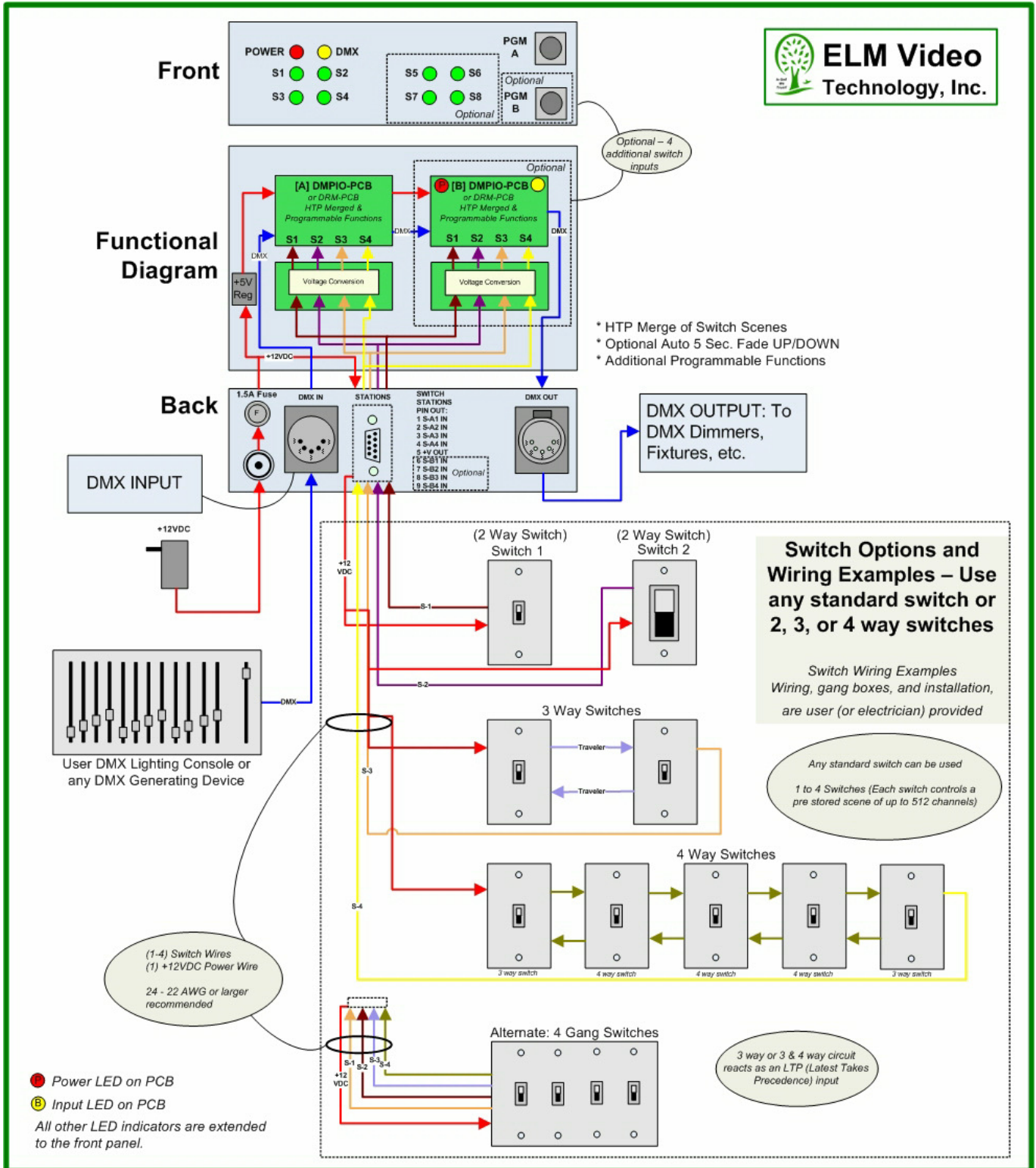

## SPECIFICATIONS

DMX CONTROL WARNING:	NEVER use DMX data devices where human safety must be maintained. NEVER use DMX data devices for pyrotechnics or similar controls.
Manufacturer:	ELM Video Technology, Inc.
Name:	DMX Multi Station Controller
Functional Description:	DMX input and output with optional external slider panel(s) or switch(es) with optional merge panel scene data with incoming DMX and manipulable outbound DMX.
Chassis:	Anodized Aluminum .093" thick RoHS compliant.
External Power Supply:	100-240 VAC 50-60 Hz, Output: Regulated 12VDC/2A
Power Connector:	5.5 x 2.1 x 9.5
External Fuse:	2.0 Amp 5 X 20 mm
PCB Fuse:	.5 ~ .75 Amp for each
DC Current:	Apx 240mA (output full DMX load of 60mA) per DMPIO PCB installed
Model Number:	DMSC-12V3/5P
UPC:	
Operating Temperature:	32°F to 100°F
Storage Temperature:	0°F to 120°F
Humidity:	Noncondensing
Non-Volatile Memory Writes:	Minimum 100K, Typical 1M
Non-Volatile Memory Retention:	Minimum 40 Yrs, Typical 100 Yrs
Station I-O Connector:	DB9 9 Pin female serial connector
Switch Input Voltage Max/Min:	+12VDC / +6VDC (at input)
Switch Input Current Max/Min:	10mA / 6mA
Data Type:	DMX (250Khz)
Data Input:	DMX - 5 (or 3) pin male XLR, <i>Pin 1 - (Shield) Not connected, Pin 2 Data - , Pin 3 Data +</i>
Data Output:	DMX512 output 250 kHz, 5 and/or 3 pin female XLR <i>Pin 1 - Power supply common, Pin 2 Data -, Pin 3 Data +</i>
Dimensions:	3.7 x 6.7 x 2.1 inches
Weight:	1.5 pounds