

DX10V User Guide

DMX to 0 ~ 10 Volt Converter

Hardware Revision 6, Software Revision 2.00

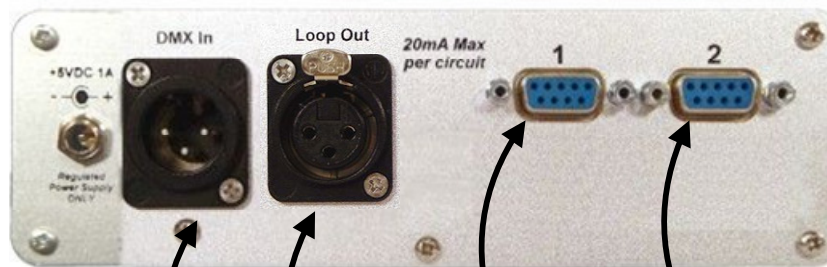
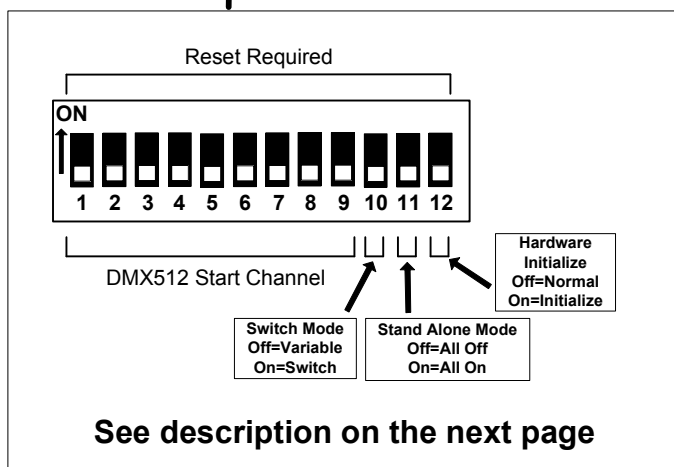

DMX Input
(3 or 5 Pin)

(Optional) DMX Loop Out
(3 or 5 Pin)

Outputs 1-8
(As equipped)

DB9 #1 PIN OUT:
Pin 1 - Ground
Pin 2 - Out 1
Pin 3 - Out 2
Pin 4 - Out 3
Pin 5 - Out 4
Pin 6 - Out 5
Pin 7 - Out 6
Pin 8 - Out 7
Pin 9 - Out 8

Outputs 9-16
(As equipped)

DB9 #2 PIN OUT:
Pin 1 - Ground
Pin 2 - Out 9
Pin 3 - Out 10
Pin 4 - Out 11
Pin 5 - Out 12
Pin 6 - Out 13
Pin 7 - Out 14
Pin 8 - Out 15
Pin 9 - Out 16

DMX10V User Guide

Description

The DMX10V is a DMX to 10 Volt Converter / Switch / Solid State Relay Driver. Control any 0-10 volt analog equipment with a DMX source such as a DMX lighting board or any device that generates a DMX (or DMX512) signal. If solid state relays are being controlled then the "switch mode" can be used for switching the outputs.

In the **VARIABLE MODE** the output voltage will vary from 0 to 10V in respect to the corresponding DMX level. For example if the DMX start channel is assigned to 10, and the level on channel 10 is 127, then the 1st output will be +5 volts, 0 = 0 volts, 255 = 10 volts etc. Each output will source 20mA (sinks 10mA). Useful for several applications including converting 10V dimmers (insure your dimmers work within these specifications).

In the **SWITCH MODE** the output voltage will either be full ON or full OFF (0V or 10V) in respect to the corresponding DMX level. Useful for non varying control voltages or driving Solid State Relays (SSR) for example. The Switch output function has a threshold of 50% that will cause the outputs to either be fully on or off. To eliminate unwanted changes at the 50% level, a padded value has been implemented. To turn ON the respective output, the DMX level must be 131 or above, to turn OFF, the level must drop to 125 or below. *In the stand alone Pot mode insure the potentiometer is either fully clockwise or fully counterclockwise to prevent intermittent or unwanted changes.*

DMX512 Input connects to the pins shown above from the DMX512 input XLR connector pins 2 and 3 respectively. Set the terminating switch to "ON" if the DMX signal ends at the DMX input terminal. If the DMX input terminal is looped to another DMX device (limit 32) then set the terminating switch to "OFF".

Stand Alone Mode – If a DMX signal is not present the Stand Alone Mode is active. The outputs can be set to be OFF or Variable via the potentiometer.

Dip Switches NOTE – A RESET/REPOWER IS REQUIRED FOR ANY DIP SWITCH SETTING CHANGES

Dip Switch's 1~9: sets the DMX512 start channel (*see the DMX512 Channel Assignment Document*). The 1st 10 volt output is controlled by the assigned DMX channel, the 2nd output is controlled by the assigned DMX channel +1 (consecutively) and so on.

Dip Switch 10: sets the output mode for all outputs - OFF (down position) = VARIABLE MODE – the outputs vary with the respective DMX levels, ON (up position) = SWITCH MODE - outputs either ON or OFF set by the threshold values mentioned above.

DIP Switch 11: OFF (down position) = In the Stand Alone Mode (no DMX is present on the input terminal) all of the outputs will be OFF, ON (up position) = In the Stand Alone Mode all of the outputs will turn ON.

DIP Switch 12: OFF (down position) = Normal Operation, ON (up position) = Hardware Initialization Mode.

When installing or uninstalling a sub module, repower with this switch ON and the yellow LED will flash. Turn OFF and repower. This will activate or deactivate the specific modules. This sets the internal software settings for the attached hardware.

LED Indicators - LED's to indicate the status of the DMX10V. The power LED will illuminate indicating power is applied.

DATA LED: ON = indicates DMX data is being received.
OFF = indicates no DMX data is being received and the unit is in Stand Alone Mode
SLOW BLINK = DMX receive error – [overrun error] (reset clears)
FAST BLINK = Communications error(s) with the output circuits (reset clears).

If error continues reinitialize the hardware with the instructions above.

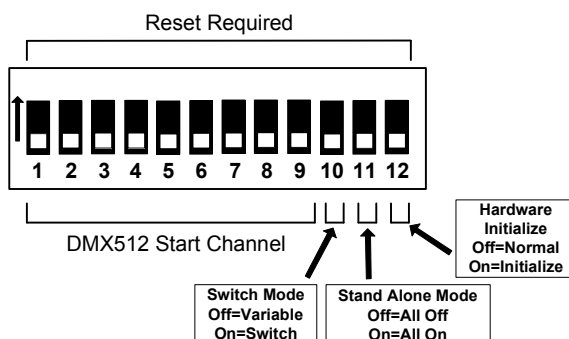

DMX10V User Guide

Specifications



**ELM Video
Technology, Inc.**
"Innovative DMX and MIDI Products"

pg 3 of 4

DMX CONTROL WARNING: NEVER use DMX data devices where human safety must be maintained.

NEVER use DMX data devices for pyrotechnics or similar controls.

Manufacturer: ELM Video Technology

Name: DMX 0 to 10 Volt Analog Converter Switch Relay Driver

Description: The DX10V converts a DMX-512 input to a variable 0 to 10 volt analog output.

MPN: DX10V-4-DC3P

Model: DX10V

UPC: 0616453087996

CHASSIS: Anodized Aluminum .093" thick RoHS compliant

Internal Fuse: SMT 750mA

Power Input: +12VDC apx 400mA (values apx, some circuits may vary)

4 Channel: no load:64mA full load 145mA

8 Channel: no load 70mA full load 230mA

12 Channel: no load 76mA full load 316mA

16 Channel: no load 82mA full load 402mA

Voltage Output: 0~10VDC, (500 ohm minimum load)

Source Output Current: 20mA Max each

Sink Output Current: 10mA Max each

DATA TYPE: DMX (250Khz)

Data Input: 5 (or 3) pin female XLR,

[Pin 1 Not connected, Pin 2Data -, Pin 3 Data +]

Data Loop Output: *(If equipped)* 5 (or 3) pin female XLR,

[Pin 1 Looped from pin 1 of input XLR, Pin 2Data -, Pin 3 Data +]

Dimensions: 3.7 x 6.7 x 2.1 inches

Weight: 1.5 pounds

Operating temperature: 32°F to 100°F

Storage temperature: 0°F to 120°F

Humidity: Non condensing

Refresh Rate Per Second: 4 Ch's = 1162, 8 Ch's = 571, 12 Ch's = 384, 16 Ch's = 285

(amount of times per second the outputs are updated)

Output Connections: DB9 Female

External Power Supply: +12VDC wall mount

Voltage Input: 100 ~ 132 (or 240) VAC

Current Output (Min): 1 Amps

Power (Min): 12 Watts

Polarization: Positive Center

Output Connector: Barrel Plug, 2.1mm I.D. x 5.5mm O.D. x 9.5mm