

DMX Standard Wall Switch Controller User Guide

DSC5 v2.00



1-4 Gang Options

DSC5 OVERVIEW

The DSC5V DMX controller uses a standard wall switch available with 1 - 4 switch(es) to control a standard DMX lighting systems. Store up to 4 static scenes and then recall just by turning on the respective switch. Easily turn on DMX controlled lights without having to turn on or use a DMX lighting board or controller. For example switch 1 could be "Band Practice", switch 2 "Stage Lights", switch 3 "Audience Lights", switch 4 "Balcony". Simply turn on any of the switches and the pre recorded scene will turn on the DMX lights, with an optional 5 second fade. If the "Merge" function is turned off then any DMX input will *override* the switches and take control allowing a DMX controller to control the lights. Turn off the DMX controller and the switches again are operable. The switch/scenes are HTP (highest takes precedence) merged with each other allowing any or all switches to turn on it's respective scene. DMX scenes are easily recorded to any of the switches from the front of the unit.

- Record up to 4 DMX scenes
- Optional 5 second fade up/down
- Optional Merge/Override DMX input function

CONNECTION

There are several ways the unit can be installed. **Example 1** shows the unit installed as the final device before the data is sent to the DMX dimmers and fixtures. In this configuration the final DMX signal that feeds the dimmers and/or lights, loops through the DSC5 wall switch unit, allowing the switches to control the dimmers and/or lights.

Example 2 (see EXAMPLE 2 below) shows the unit installed as part of the DMX source by merging the DSC5 units' DMX with any other DMX generating device(s). In this configuration the DSC5 generates a DMX signal and then is merged with several merge options using our DMG Merger products.

In either configuration, once the DSC5 wall switch unit has the scenes recorded, the DMX input could be removed and the unit simply generates a DMX signal to control the dimmers and/or lights in a standalone DMX controller.

EXAMPLE 1

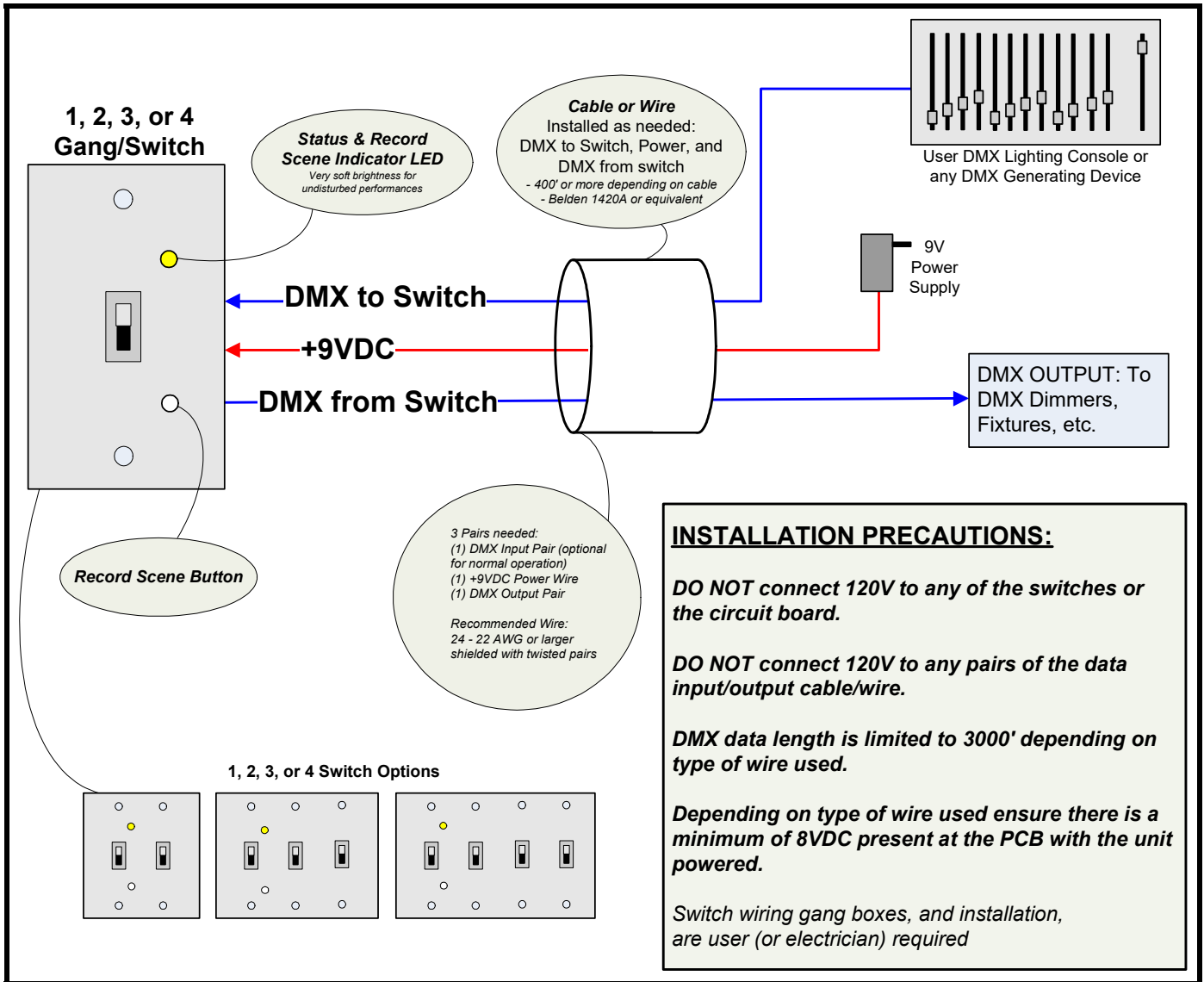

EXAMPLE 2

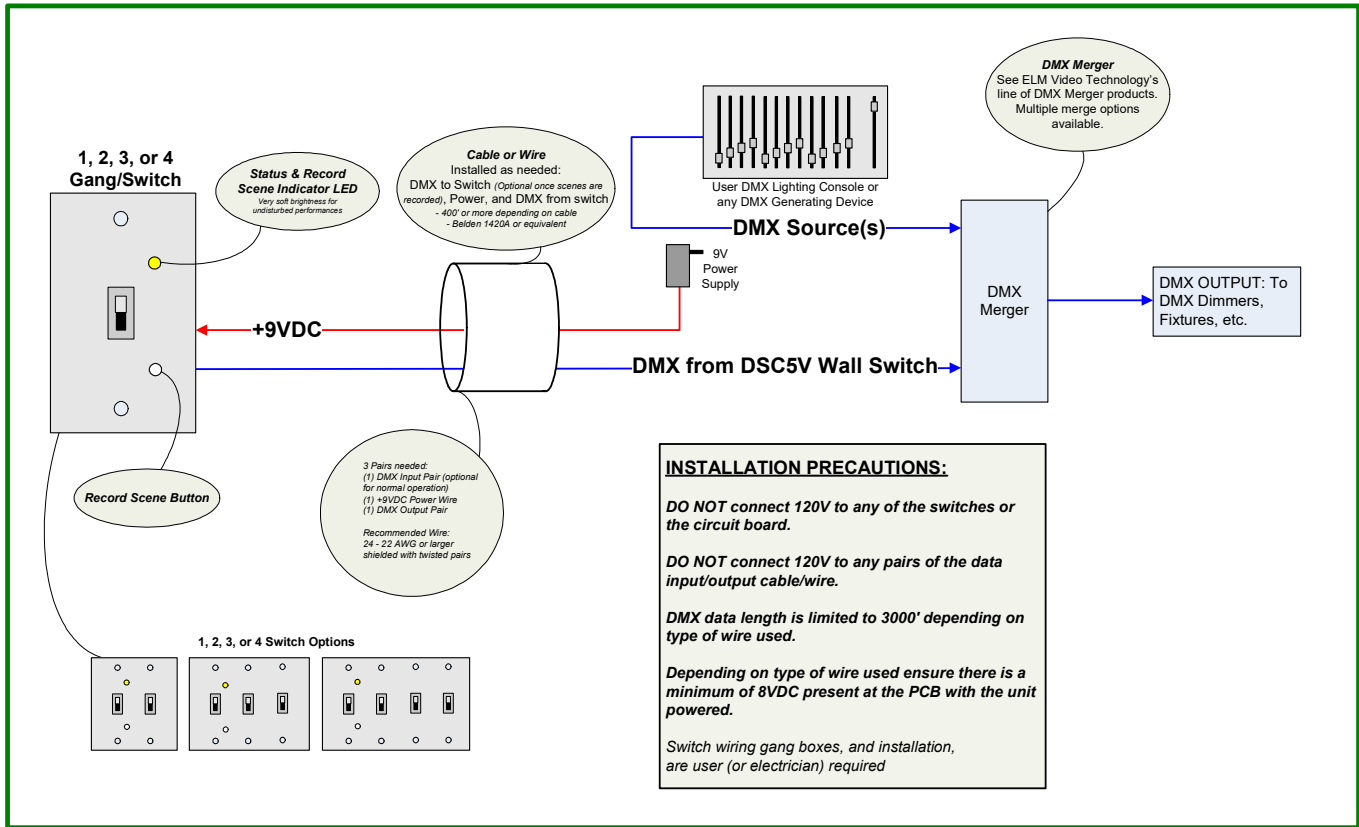

INSTALLATION PRECAUTIONS:

DO NOT connect 120V to any of the switches or the circuit board.

DO NOT connect 120V to any pairs of the data input/output cable/wire.

DMX data length is limited to 3000' depending on type of wire used.

Depending on type of wire used ensure there is a minimum of 8VDC present at the PCB with the unit powered.

Switch wiring gang boxes, and installation, are user (or electrician) required

PCB WIRING DIAGRAM:

DIP SWITCH SETTINGS
Reset Power to Activate

1: - TRANSITION / FADE RATE
ON - 5 SECONDS
OFF - IMMEDIATE

2: - DMX LOSS DIRECTIVE
OFF - Transition/fade to switch/scene(s)
ON - DMX output is turned off

3: - OVERRIDE / MERGE
OFF - DMX Input will **OVERRIDE** all switches
ON - DMX will **MERGE** with enabled switches

4: Unused

SCENE RECORD
With DMX Input and all switches off

1. Press and hold 3 sec [slow blink]
2. Turn on one switch to record [rapid blink]
3. Press and hold 3 sec [two confirm blinks]

WIRE EXAMPLE USING CAT5 COLOR CODE

WIRE	CONNECTION
White/Blue	DMX - to Switch
Blue/White	DMX + to Switch
White/Orange	+5V to Switch
Orange/White	Power Supply Gnd to Switch
White/Green	DMX - from Switch
Green/White	DMX + from Switch
Shield	Switch Gnd

Install the appropriate DMX and power wires. Insure the path is safe and away from the public and not prone to damage as these wires carry the DMX signals and power to/from the unit for the lighting system. It is recommended to install inside a conduit. Connect the DMX generating device, power supply, and DMX output wires source to the installed wires, check for accuracy, check the polarity of the power supply on both ends before applying power. Turn the unit on and check for that the power LED (Green) is illuminated. Send DMX data, the data LED (Yellow) should be illuminated if valid DMX is present. If the input voltage is to low or to high the VOLT LED (RED) will be illuminated, If so, disconnect the input power and check that it is within the voltage range of the specifications (see SPECIFICATIONS page). Record scenes as needed and check for proper operation.





DO NOT CONNECT 120VAC TO ANY OF THE CONNECTIONS OF THIS UNIT.

Connect DMX source wires (lighting board or similar) into the input screw terminals labeled: -2 and +3 (XLR connector pins 2 and 3 respectively) *See PCB Wiring Diagram, and WIRE Example.* The input is terminated locally so loop thru is not recommended. Connect the DMX output destination wires to the screw terminals labeled: Gnd, -2, and +3. Connect the power supply to positive and ground wires to the PWR in terminals - **CHECK POLARITY BEFORE CONNECTING, REVERSE OR OVER VOLTAGE MAY DAMAGE THE UNIT.** Once connected the power LED will illuminate indicating power is present. Under normal operating conditions and all DMX input and outputs connected, check the voltage at the PCB and insure that it's in the range of 8VDC to 12VDC. This is important to insure proper operation.

PCB DIP SWITCH SETTINGS

Set the dip switches for the desired operation and **RESET POWER** to activate the new settings.

To access the dip switches, remove the front cover to reveal the PCB.

 1 ON OFF	<p>D.S. 1: - TRANSITION / FADE RATE - Sets the transition rate for switch/scene setting changes. If a respective scene/switch is turned on or off the scene recall will either be immediate or have a 5 second transition rate.</p> <p>Dip Switch 1 OFF - Transition/fade rate = IMMEDIATE Dip Switch 1 ON - Transition/fade rate = 5 SECONDS</p>
 2 ON OFF	<p>D.S. 2 - DMX LOSS DIRECTIVE - If DMX is lost or no DMX is present on the input this setting determines the state of the DMX output of the DSC5 wall unit. <i>NOTE: If ON then the switch outputs will not be sent unless there is DMX present on the input and the unit is in the MERGE mode. Otherwise once the DMX input signal is lost the output will turn off.</i></p> <p>Dip Switch 2 OFF - The DMX output is always on/active Dip Switch 2 ON - If the DMX input is lost then the DMX output is turned off</p>
 3 ON OFF	<p>D.S. 3: - OVERRIDE SCENE(s) or MERGE/COMBINE with DMX INPUT - IF DIP SWITCH 3 IS OFF = [OVERRIDE] setting, all enabled scene(s) will only be active IF there is not a DMX input signal present, (either turning off the DMX lighting board or disconnecting or unplugging the DMX input). IF DIP SWITCH 3 IS ON = [MERGE] - The DSC5 wall unit will merge/combine all enabled scene(s) with incoming DMX. <i>NOTE Dip Switch 2 must be OFF for this setting to be active.</i></p> <p>Dip Switch 3 OFF - DMX Input will OVERRIDE all switches Dip Switch 3 ON - DMX will MERGE with enabled switches</p>
 4 ON OFF	<p>D.S. 4: - Aux (Future Use)</p>

Plan all DMX changes carefully, understand how each mode will react, and thoroughly test each device after any configuration changes. To abort any settings while in the programming mode, toggle the power to reset the unit, and reenter if desired.

LED BLINK RATES

Rate	Description
OFF	No DMX is being received
ON	Valid DMX is being received
1x	DMX Input data error has occurred since powered OR unit is in Record Scene Mode
2x Blink	Record Scene Mode with the selected switch to be recorded turn on
2 Flashes	Respective scene has been recorded
3x Flicker	Record Scene Error, button is pressed with a switch on OR no DMX is present

SCENE RECORDING

1. Insure a valid DMX signal is present indicated by the DMX input LED on.
2. Preset a desired scene from the DMX lighting board or DMX generating device.
3. Enter the PGM Scene Record Mode by press and holding the *Record* button for 3 seconds, the data LED will blink at the 1x rate. Turn on only 1 switch that the scene is to be recorded to, the data LED will blink at the 2x rate. Press and hold the *record* button for 3 seconds, the data LED will flash 2 times indicating the scene has been recorded. *To abort recording, wait 20-30 seconds to allow the unit to time out.*

Repeat steps to record each scene.

While in the scene record mode inactivity for 30 seconds will automatically cancel and exit.

SPECIFICATIONS

DMX CONTROL WARNING:

NEVER use DMX data devices where human safety must be maintained
NEVER use DMX data devices for pyrotechnics or similar controls

Manufacturer:	ELM Video Technology
Model:	DSC5V
Name:	DMX Standard Wall Switch Controller
MPN:	DSC5V-1G (2G, 3G, or 4G)
Dimensions:	1 Gang - 4.75"H x 3"W x 2"D, 4 Gang 4.75"H x 8.4"W x 2"D
Switch Input(s):	+5VDC Maximum
DATA TYPE:	DMX (250Khz)
DATA INPUT:	DMX - (Shield) Not connected, Pin 2 Data - , Pin 3 Data +
DATA OUTPUT:	DMX outputs - Pin 1 - (Shield) Power supply common, Pin 2 Data -, Pin 3 Data +
Weight:	.75 pounds
Voltage Input Nominal:	+9VDC
Voltage Input Minimum:	+7.5V Minimum at circuit board input
Voltage Input Maximum:	+12.5V Max at circuit board input
Current:	125mA
Internal FUSE:	500mA PCB SMT
External Power Supply:	+9VDC wall mount
Voltage Input:	100 ~ 240 VAC 50/60hz