

DXRL-PCB Relay Connection Diagram Example

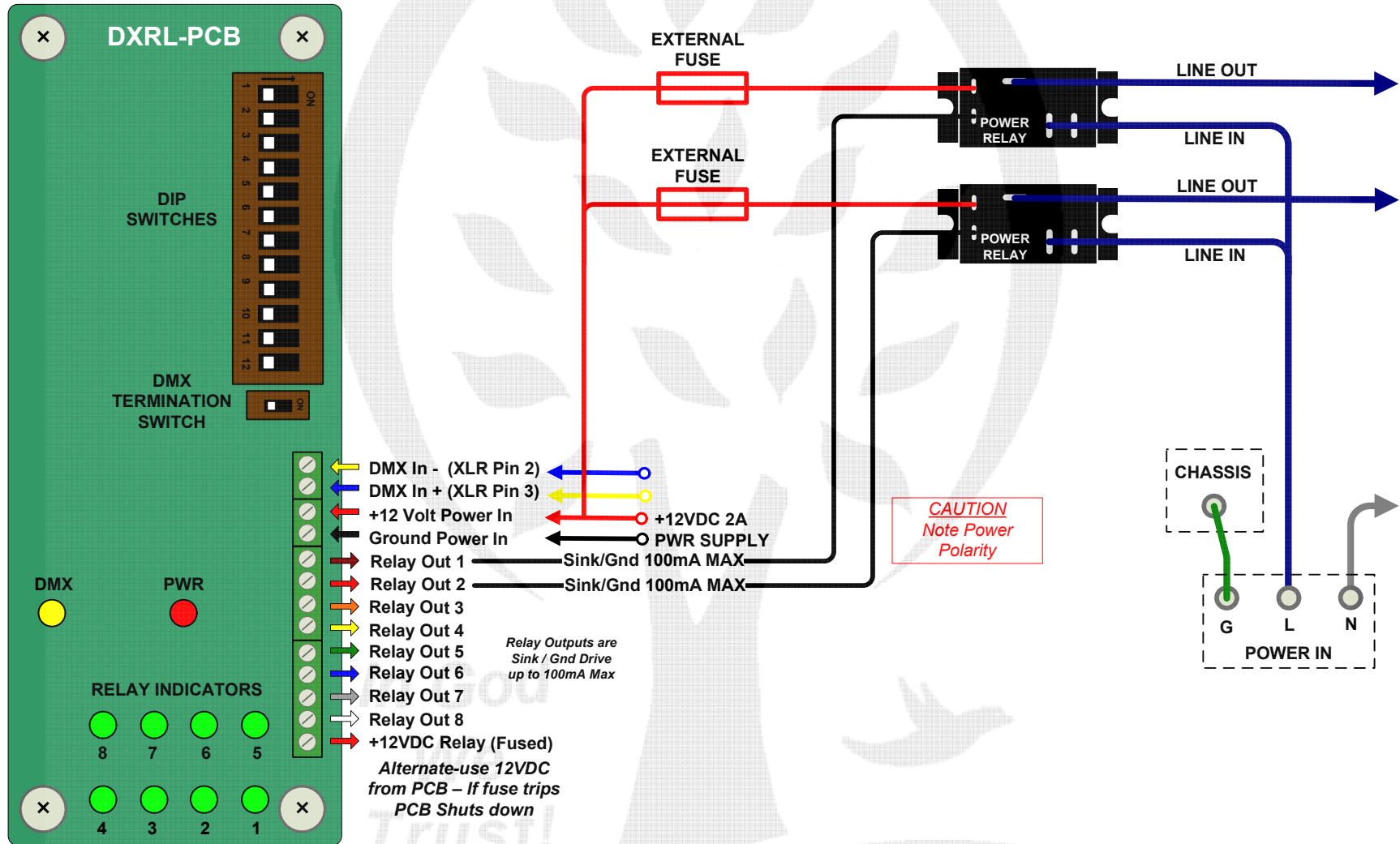

DXRL-PCB Relay LED Display Alternate

*This setup option will flip the LED display between
the left and right columns.*

This setup only changes the order of the LED's and output order.

To alternate the display option, turn on dip switch 12, and repower. Turn off then on dip switch 12 [3] times-a confirmation blink will occur. Ensure dip switch 12 is off and repower to resume normal operation.

The LED's and outputs will alternate as shown.

Alternate A

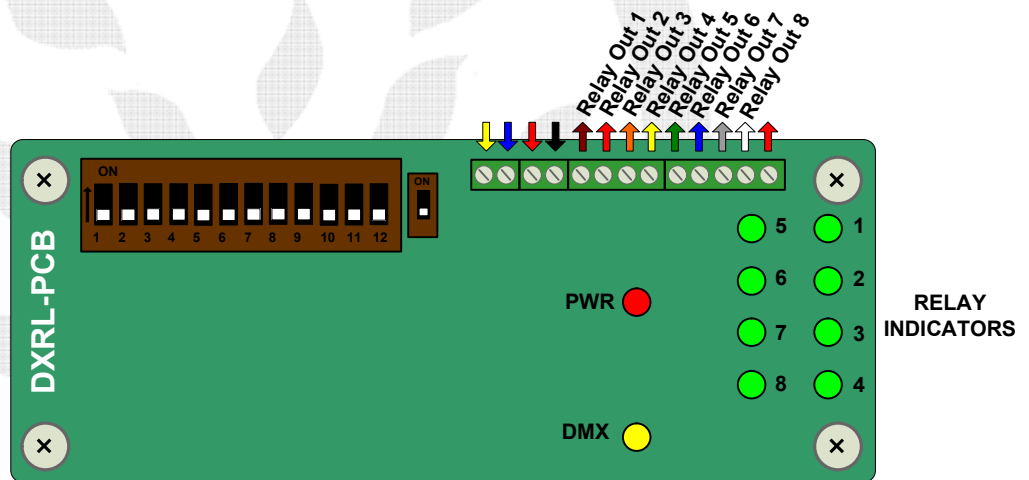

Alternate B

