

**BEFORE PRINTING TURN OFF ANY SIZE ADJUST SETTINGS ON YOUR PRINTER,
VERIFY PRINTED HOLE SIZES BEFORE DRILLING**

DS8D r2 DRILL TEMPLATE

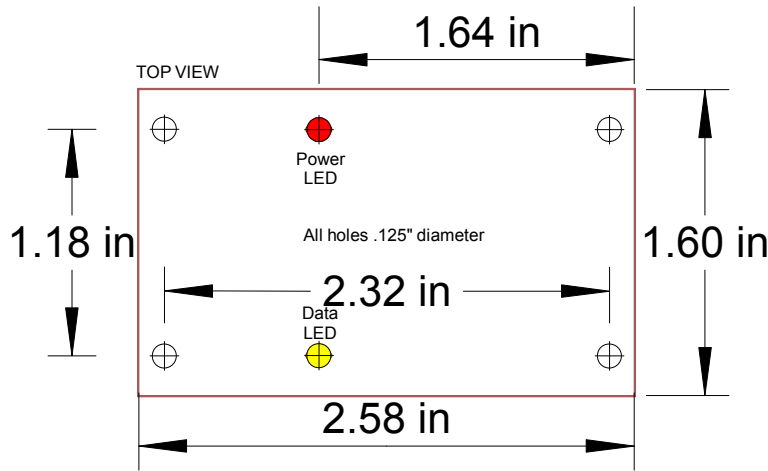

Cut and tape this template on the chassis to use a guide.
Re space the connectors and PCB as desired.

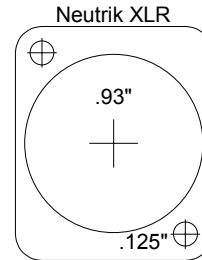

XLR Dimensions
For Neutrik #'s
NC5MD-L-BAG-1
NC5FD-L-BAG-1
NC3MD-LX-BAG-1
NC3MD-LX-BAG-1

Any 3 or 5 pin XLR connector can be used, chassis mount or in line.

Handle the PCB with static electricity precautions - touch a grounded source to discharge static electricity before touching the PCB

WIRING DIAGRAM

NOTE: If the LED's are not connected the PCB LEDs' ground is the SQUARE pad and the LED's shorter pin is the ground pin.

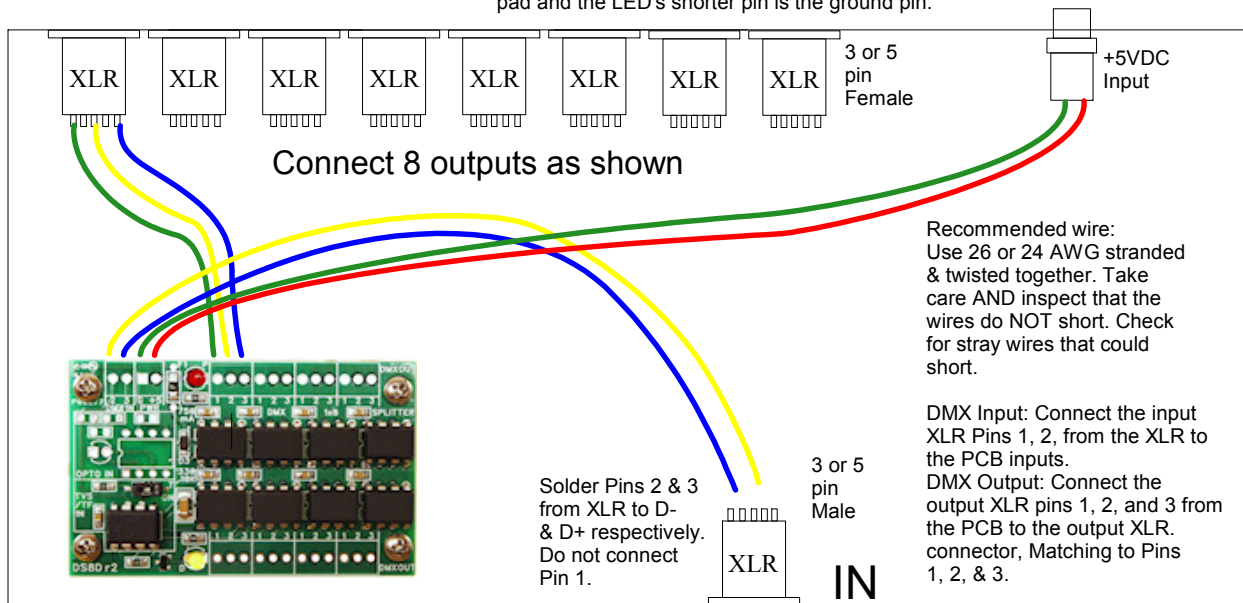

IMPORTANT NOTE:
If equipped with standard input, terminate the input by setting switch to "ON".
If equipped with optical input do terminate input as the optical input is self terminating.

It is recommended NOT to daisy chain the DMX Input, with either the standard or optical input version.