

# MA1

## Midi Analyzer

M Series Module



**ELM Video  
Technology, Inc.**  
*"Innovative DMX and MIDI Products"*



## Table Of Contents

Important Safeguards .....	2
Product Overview .....	3
Decode Mode .....	3
Hex Mode .....	3
Switch & Connection Overview .....	4
Installation .....	5
Power and Switch Jumper .....	5
Operation .....	8
Program Mode .....	8
Decode Mode .....	9
System Exclusive Messages .....	9
Special Decode Features .....	10
Running Status .....	10
System Real Time Messages .....	10
Hex Mode .....	10
Scroll Layout Table .....	11
LCD Status Quadrant Table .....	11
Troubleshooting .....	12
Specifications .....	13

## **Important Safeguards**

Read and follow all instructions BEFORE installing or using this product.

Do not attach any product or accessories that the manufacturer does not recommend.

Keep in a well ventilated environment.

Never use or store the unit in places that are:

- Subject to temperature extremes (direct sunlight, in an enclosed vehicle, near a heating duct)
- Wet, damp and humid areas
- Dusty
- Subject to high levels of vibration

Use proper Power Sources. This product should be operated only from the type of power source indicated on the marking label or as is described in this manual.

Route power cord safely. Don't allow twist's, bend the power cord, or place heavy objects on it.

Ground your equipment whenever possible.

Do not attempt to service this product unless noted otherwise.

If the unit stops working for any reason, unplug the power and other connections until repaired.

This unit should be used only with a rack or chassis that is recommended by the manufacturer.

Unplug the device when not in use.

Keep away from small children.

## **PRODUCT OVERVIEW**

The MA1 is a fully input isolated midi signal analyzer and is part of a modular system for quick, easy and CUSTOM configuration. The MA1 module receives midi messages from a keyboard, computer or any midi instruments or device, decodes and displays the messages. By entering the "HOLD" mode, the last few messages can be viewed. Whether you are a programmer, engineer, musician, or show control operator, this device and module system is ideal. This compact module can be programmed for many different functions and custom configurations. By ganging MA1's together, each one could be programmed to filter out selected messages, and at a quick glance the latest information is displayed. The MA1 has flexibility with power switch jumper settings so each module can be independent or powered by one unit. The MA1 has 2 receive modes of operation:

## **DECODE MODE**

In the Decode mode the display shows the type of message, Channel number, and decimal equivalent of the data. The 'Note' information can be viewed as the decoded note or as a note number. Middle C can be changed from C3, C4, or C5. In the HOLD mode the last few bytes can be displayed and scrolled through, including a message counter. Any message type can be filtered out. An indicator shows if 'Midi Time Code' (F1), 'Time Clock' (F8), and 'Active Sensing' (FE) messages present whether they're filtered or not. System Exclusive messages are displayed with all the associated bytes that can be scrolled through independently too and displays a total byte count and an individual byte counter.

## **HEX MODE**

In the Hex mode the data is displayed in a Hexadecimal format for technical viewing, and displays the data AS IS without any decoding. In the HOLD mode the last 112 bytes can be displayed and scrolled through, including a byte counter. 'Midi Time Code' (F1), 'Time Clock' (F8), and 'Active Sensing' (FE) messages can be filtered out. An indicator shows if those messages are present whether they're filtered or not.

The bottom right of the display shows errors, filter on/off, and if MTC, Timing clock and Active Sensing are present. Both modes retain 112 bytes of data that allows the user to 'HOLD' and view by scrolling left and right through the data.

## SWITCH & CONNECTION OVERVIEW

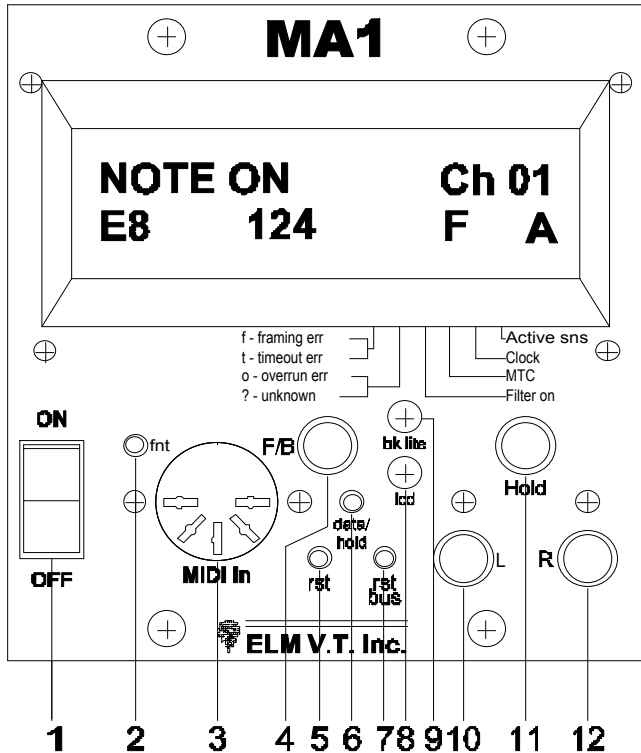

1. Power Switch - Jumper setting will determine if it will power the local module only or the local module AND the bus. (Other modules may have a jumper for using bus power or not.)
2. LED - if lit indicates the front MIDI connector is selected
3. MIDI IN - Front input.
4. INPUT SELECT - Selects Front/Rear midi input connectors. Up position selects REAR connector, down selects FRONT connector for midi input.
5. RST - Resets local module only.
6. DATA/HOLD - NORMAL operation indicates data is present, constant ON indicates 'HOLD' mode.
7. RST BUS - Resets bus (or all 5 modules in the rack if applicable).
8. LCD - Liquid Crystal Display contrast adjustment.
9. BK LITE - Liquid Crystal Display BACK LIGHT brightness adjustment.
10. L - Left scroll in HOLD mode, toggles settings in PROGRAM mode.
11. HOLD - Toggles between NORMAL and HOLD mode. If pressed and held during power on or reset the MA1 will enter the PROGRAM mode.
12. R - Right scroll in HOLD mode, toggles settings in PROGRAM mode.

## Installation

### Note

\* Take care not to touch the component pins or the inner pins of the connectors. Electrostatic discharge may cause permanent damage to the unit.

Before placing the module into the M Series frame make any necessary jumper changes. For each chassis one and ONLY one module should be set up as the 'MAIN' module all other modules are considered 'SECONDARY' modules. The MAIN module has the power supply connected and supplies the other 4 SECONDARY modules the power via the BUS (ribbon cable supplied w/ the M series enclosure) or the 2 conductor Power Cable. The MAIN module can also send the received data from the MIO rear input module (sold separately) and then send the data via the ribbon cable. Or the MA1 can be operated independently (not connected to the BUS). Factory jumper settings are not preset and must be properly jumpered to operate.

**Power and Switch Jumper's** - The front panel power switch (1) can be used for 2 functions. If the switch connector is plugged into J11 then the switch will toggle power to the local module only. If an MIO module (Input/Output and Power distribution module sold separately) is installed directly behind the MA1 to be installed, it is necessary to plug the switch connector into J1. (*note - The power switch connector orientation does NOT matter.*) This will switch the power for this module and any other module connected to the MA1 module either via the ribbon BUS cable or power connectors.

The MA1 can be installed in any of the 5 module positions using (4) 6-32 screws (supplied with the M series enclosure). Once the jumper settings are made and the module is mounted flip the unit over and attach the ribbon cable and/or 2 conductor power cable (supplied with the M series Enclosure), to the other modules within the chassis, note the polarizing plug faces the edge of the board on the Ribbon cable connector (J5). Install a blank panel on the back behind the MA1 if it's a secondary module or install an MIO module directly behind the MA1 if it is the main module. Secure the module on the rear using (4) 6-32 screws (supplied with the M series enclosure).

Never use any modified or other modules other than genuine ELM V.T. Inc. modules.

Never allow 2 power supplies to run in parallel or 2 'Data Outputs' (J9) to be connected at the same time within a chassis.

### Power Setting EXAMPLE 1

Power supplied to this local module and to any module(s) connected via the power connector. The switch will control all modules connected via either the BUS or Power connector.

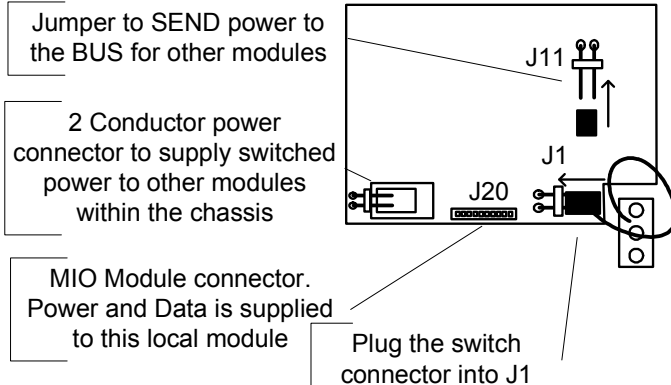

### Power Setting EXAMPLE 2

Switch turns power on/off to this local module and any modules connected to the Power Connector.

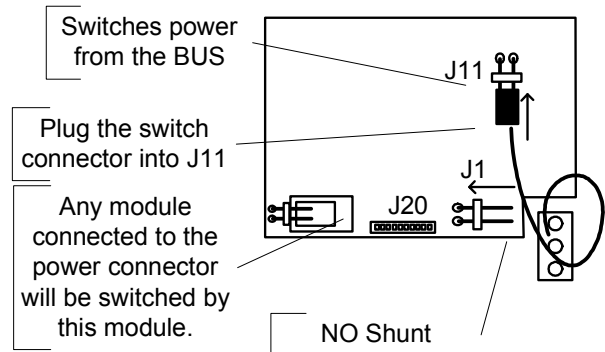

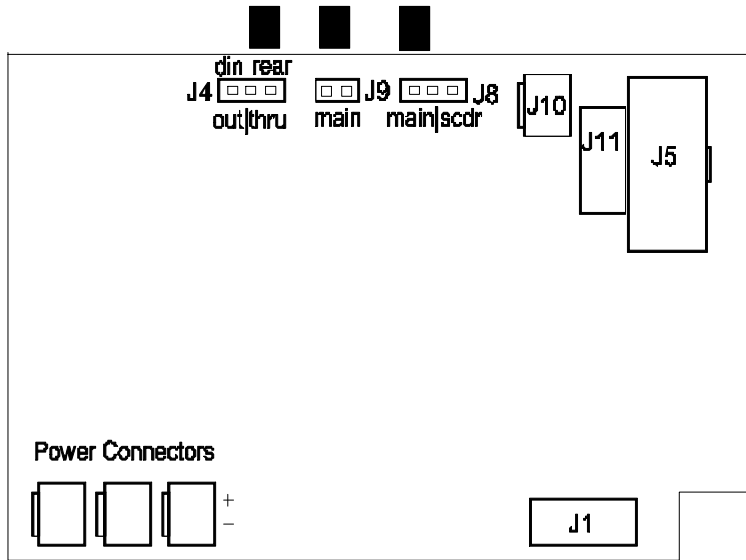

## JUMPER SETTINGS:

- J1 Power IN Switch connector
- J11 Power TO/FROM bus or Switch power from the bus to the local module
- J4 Rear Din Connector 'OUT' or 'THRU' setting
- J5 Ribbon (Bus) cable connector
- J8 Data input select - Jumper 'S' if secondary, 'M' if main
- J9 Data output to ribbon cable (only 1 per chassis should be connected)

J4 - Jumper J4 in the 'THRU' position if the REAR input Din Connector data is to be echoed. (Data on the output is the SAME as the data coming in on the rear input.) Jumper to the 'OUT' position if the DIN INPUT SELECT SWITCH (Front/Rear Din Connectors selector) data should be echoed. (Data on the output is the same data that is SELECTED by the front selector switch. NOTE that if the BUS selection is made in the software that this data will NOT be sent to the output.)

J8 - Jumper J8 Jumper to 'MAIN' if the MA1 is the main unit, jumper to 'SDR' if the MA1 is used as the secondary unit.

J9 - Jumper J9 jumper if the MA1 is the main unit, this sends data to the bus to supply the secondary modules with midi data. ONLY 1 unit per chassis should have J9 jumpered.

UNPLUG the power source BEFORE attaching power and data cables. After making the necessary jumper settings, use the 6-32 screws to mount the unit in the desired position. If the module is to be the 'MAIN' module it is recommended (but optional) to place it in the left most position. From the back, plug the 10 pin ribbon cable in the PCB connector (J5) if there is another module in the chassis that has a Ribbon Cable connector and attach the power cable harness to any module within the chassis that only has a 2 conductor power connector. Both can be used. The power connector can be attached to the MIO module to supply power to any module with a 2 conductor power connector input for unswitched power. If the 2 conductor power cable is connected to a module and that module has a switch then the power will be turned on/off via the switch. After installing, inspect the ribbon cable for proper alignment before applying power. Then mount the MA1 rear panel using the 6-32 screws.

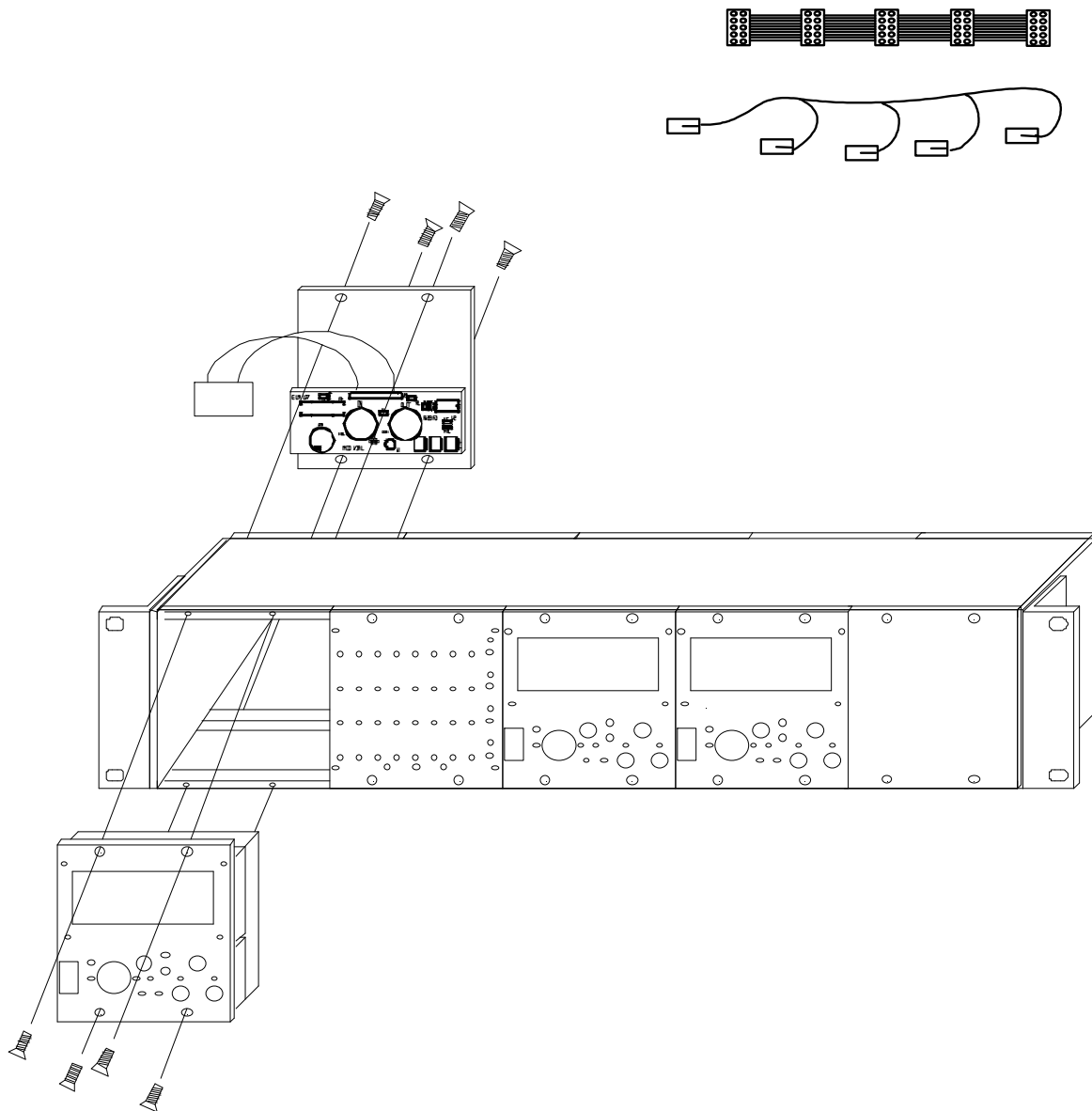



## Operation

After the jumpers are set and assembly is complete, power the module. There are 2 modes of operation: **PROGRAM** and **RECEIVE** mode. In the receive mode there are 2 modes: DECODE and HEX, selected in the program mode. The module powers in a receive mode. Within these modes the last messages or bytes can be viewed by pressing the 'hold' button (11) and the user can scroll the data by using the Left (10) and Right (12) buttons. There are 3 midi data inputs: the din connector on the back, the din connector on the front, and the internal BUS which is sent from the module in the chassis that is set up as the 'MAIN' unit. To toggle between the DIN's and the BUS inputs press the 'hold' (11), 'left'(10) and 'right'(12) buttons and reset (5) the module. The selected input will be displayed in the upper right until the 1st message is received. If DIN is selected the FRONT/BACK switch (4) will toggle these connectors respectively. If the front is selected the red LED will be lit.

**PROGRAM MODE** - To enter the pgm mode press and hold the 'HOLD' button and reset or toggle the power. Once in the pgm mode the current setting is displayed in the lower right. To exit the pgm mode at any time press and hold the 'HOLD' button for 2 seconds or press the reset button. The programmed setting can be toggled by pressing the left or right button. The change is stored IMMEDIATELY (what you see is the stored setting). Press HOLD to advance to the next option. The last display displays the software version. Note \*\* No midi data will be received while in the pgm mode.

- **Decode or Hex Mode** - Selects the operational mode, 'Decode mode' decodes the incoming data, 'Hex mode' displays the incoming data in a hexadecimal format without decoding.
- **'NOTE #' or 'NOTE'** - If Decode was selected then the user can select whether the 'NOTE' or the 'NOTE number' (decimal number from 0 to 127) will be displayed.
- **Middle C** - If 'note' was selected then the unit can be setup for either C3, C4, or C5 to be middle C. This only effects the displayed note bank number.
- **Filter FX 'Select' or 'ALL'** -filter 'ALL' FX commands or 'Select' allows the user to select the filter; 'Midi Time Code' (F1), 'Time Clock' (F8), and 'Active Sensing' (FE) individually.
- In the decode mode the next 6 filter options will be displayed, select 'yes' if the corresponding data should be filtered.

1. 9X - Note On
2. AX - Polyphonic After Touch
3. BX - Control Mode
4. CX - Program Change
5. DX - Channel After Touch
6. EX - Pitch Wheel

- **Restore Defaults** - Select 'yes' to load the factory default settings. The settings will be stored and the unit will return to a receive mode.

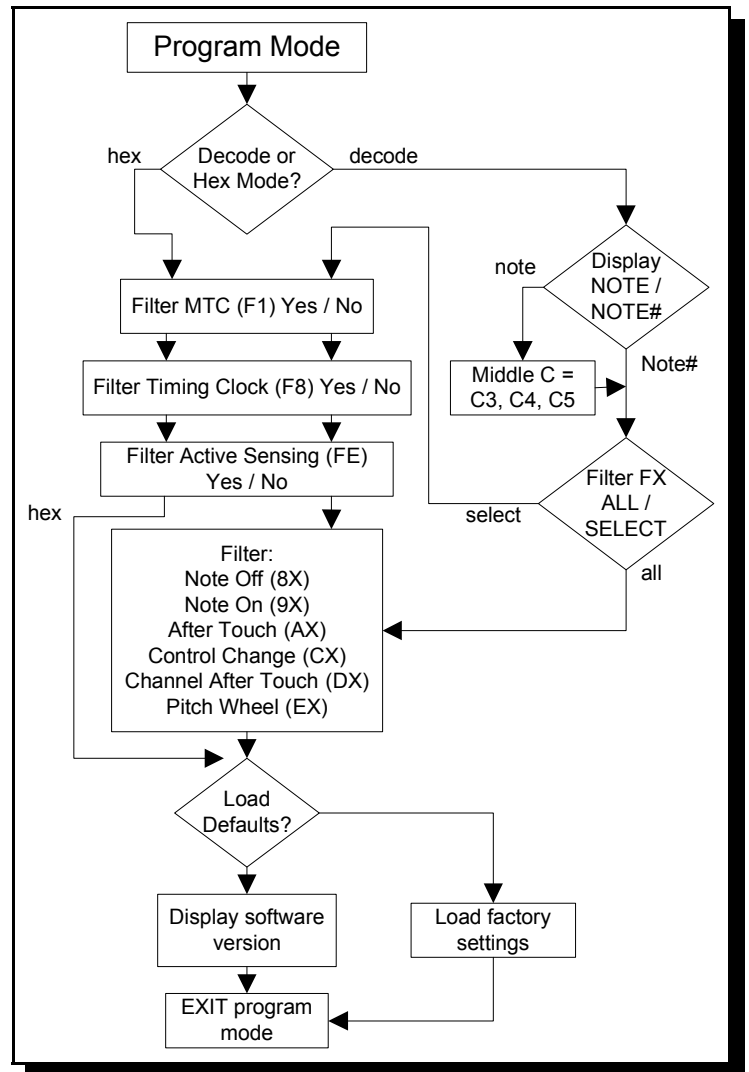

- **Display Software Version** - The displayed page shows the product type and software version. To exit press hold.

*Note.. to change the midi input from the DIN (F/R) connectors to the BUS (ribbon cable) is a software change*

**DECODE MODE** - The decode mode is selected in the program mode. Within the decode mode there is 2 modes of operation; Display and Hold mode. In the **Display** mode all incoming MIDI data will be decoded and displayed. Any or All message types can be programmed to be filtered out.

Quadrant:

**LCD Display Quadrants**

1. will be the MIDI function
2. the Channel number
3. 1st data byte in decimal format\*
4. 2nd data byte in decimal format\*
5. MA1 and received midi message's status see LCD STATUS QUADRANT TABLE 1

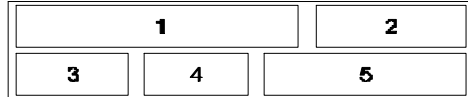

\* An 'M' = MSB (Most Significant Byte) and an 'L' = LSB (Least Significant Byte). If followed by; an 'h' indicates hexadecimal format data.

By pressing the 'HOLD' button the unit enters the **Hold** mode. The LED indicator will come on. The displayed message is the last message received. The left and right buttons will allow the user to scroll through the data. The arrows indicate more data is present in that direction. Quadrant 2 toggles between the Channel number and the message number (the last message received is message 1). The message number will increase as you scroll left and decrease as you scroll right for all messages and quadrants 3 and 4 will display the decoded information. Quadrant 5 displays the hexadecimal data of the message.

**System Exclusive Messages (F0)** - Sys Ex messages are displayed differently. Quadrant 1 displays the total number of bytes in the Sys EX message. Quadrant 2 displays the **BYTE** number directly above that byte. Once a Sys Ex message is displayed the scrolling option will change. If the Sys Ex message has more than 7 bytes (which is the display range) then the right arrow will be on, if you scroll right it will show the 8th byte within the Sys Ex message. Once your in a Sys Ex display range the arrows indicate the direction of data in that range unless your at the head or end of the range indicated by an 'F0' or 'F7', if so it will advance to the next message.

See Special Decode Feature below for special message handling.

No data is received during HOLD.

See Scroll layout table for scrolling description.

## Special Decode Features

The decode mode could add and change messages.

See the web sight 'Midi Manufacturers Association' for MIDI specifications. ( <http://www.midi.org/> )

## RUNNING STATUS

If a duplicating (status byte) message is sent more than once some devices will omit the 1st byte and send only byte(s) 2 (and 3). For example if a ['NOTE ON' Channel 3 / Note C4 / at 125 velocity] (92 60 7D hex) is sent and then a ['NOTE ON' Channel 3 / Note C#4 / at 126 velocity] (92 61 7E hex) is sent the 2nd message may actually send only ['Note C#4 / at 126 velocity] ( 61 7E hex). This is known as **Running Status**. The MA1 will **ADD** the status byte to the message.

*\*\*The hex mode will NOT add the status byte and will store exactly as it was received.*

## SYSTEM REAL TIME MESSAGES

Timing Clk, Start, Continue, Stop, Active Sensing, and System Reset (F8 - FFh) messages are sent in real time. These messages can be **INSERTED** in the middle of other messages. The MA1 considers the 'end of message' to be when the last of the data is received for that message. If a message is started and a 'Real Time Message' is sent that message will be stored 1st then when the continuing message is complete it will be stored last.

*\*\*The hex mode will NOT INSERT status byte, all data bytes will display exactly as they are received.*

**HEX MODE** - The hex mode is selected in the program mode. Within the decode mode there are 2 modes of operation; **Display** and **Hold** mode. In the **Display** mode all incoming MIDI data will be displayed in hexadecimal format. The newest byte of data will be displayed in the upper right of the display. In this mode only 3 types of data can be filtered; Midi Time Code (F1), Timing Clock (F8), and Active Sensing (FE).

Quadrant:

1. incoming hex data, newest byte far right
2. MA1 and received midi message's status

See [LCD Status Quadrant Table](#)

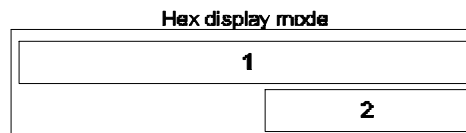

By pressing the 'HOLD' button enters the **Hold** mode. The LED indicator will come on. The hex data is shifted to the bottom row. The lower right byte is the last byte received. The upper right will show the byte number of the byte directly below. The left and right buttons will scroll through the data. The arrows indicate more data is present in that direction. The byte number will increase as you scroll left and decrease as you scroll right. The data is display exactly as it was received. *No data is received during HOLD. See [Scroll layout table](#) for scrolling description.*

Quadrant:

1. byte number of the byte below
2. MA1 and received midi message's status

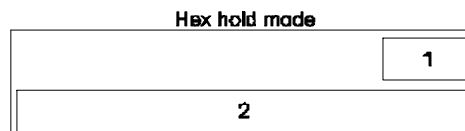

## LCD STATUS QUADRANT TABLE

position	display	Indication	Clears by	Note
1	'f'	framing error has occurred - occurs if there is an incoming data error, either powered the unit or switched modes and a message was already in progress, or could indicate a unstable connection.	reset, or check wiring or sending device	
1	't'	time out error has occurred - occurs if there is more than 2 milli second delay between bytes before a message is complete.	reset	this error is overridden by the 'framing' error
2	'?'	unknown message has been received - incorrect number of bytes received, either to many or to little.	reset	
2	'o'	overrun error has occurred - to much data is received with special features turned on such as Filtering, Running status & Real time messages (F8 - FE) which require more processing. If this error occurs - limit these features/functions. *	reset	this error is overridden by the '?' unknown message error
3	'F'	Filter is ON - any or all filters are active. Enter the program mode to show which ones are on.	pgm mode filter options	
4	'M'	Midi Time Code is being received.	midi sending device	
5	'C'	Timing clock is being received.	"	
6	'A'	Active Sensing is being received.	"	

\*(Known overflow condition example (hex) 83 24 F8 F9 FA FB FC FD FE FF 7F FE FE FE FE , ALL THESE INSERTED W/ ANY 8X - EX FILTER ON, CAUSES AN OVERFLOW AND IF MORE ARE SENT CAUSES A FRAMING ERROR TOO. (INSERT TEST 8XB 7TH TX))

Scroll Layout Table				
LEFT	<-----	message	(or byte #)	increases
<b>END</b>	<b>oldest msg (or byte)</b>	<b>up to 112 msg's (or bytes)</b>	<b>newest msg (or byte)</b>	<b>END</b>
message	(or byte #)	decreases	----->	RIGHT

## Troubleshooting

PROBLEM	CHECK
<ul style="list-style-type: none"> <li>Unit won't power up</li> <li>Switch turns off modules I don't want turned off</li> <li>Switch doesn't work</li> </ul>	<ul style="list-style-type: none"> <li>verify proper switch connector settings &amp; jumpers</li> <li>check power switch connections</li> <li>check fuse and power connections</li> </ul>
<ul style="list-style-type: none"> <li>Won't receive data on local module</li> </ul>	<ul style="list-style-type: none"> <li>verify data is being sent from source</li> <li>check the DIN/BUS software setting is correct</li> <li>make sure input switch on front panel is selected properly</li> <li>check that the data being sent is not being filtered</li> </ul>
<ul style="list-style-type: none"> <li>MAIN module will receive data but the SECONDARY modules do not</li> </ul>	<ul style="list-style-type: none"> <li>check that J9 is jumpered on MAIN module</li> <li>check that the ribbon cable is connected properly</li> <li>make sure that two data signals are not on the ribbon cable (see jumper settings section)</li> </ul>
<ul style="list-style-type: none"> <li>LCD is lit but there's not anything displayed</li> </ul>	<ul style="list-style-type: none"> <li>adjust the LCD contrast</li> </ul>
<ul style="list-style-type: none"> <li>Midi out connector is not sending correct data</li> </ul>	<ul style="list-style-type: none"> <li>check thru/out jumper setting</li> </ul>
<ul style="list-style-type: none"> <li>Sometimes I have a '?' or 't' error when I switch from Front/Back or Din to Bus</li> </ul>	<ul style="list-style-type: none"> <li>a switch was made while a message was being sent or received, either limit the data during a switch or reset the unit after switching</li> </ul>
<ul style="list-style-type: none"> <li>Sometimes the 'A' active sense indicator turns off and back on</li> </ul>	<ul style="list-style-type: none"> <li>some devices won't send an 'active sense' message if it's sending other data, this is normal</li> </ul>

## Specifications

Power Input	+5 volts DC
Power Consumption	.4 Amps at full power (LCD back light full brightness)
Input power connector	2.1 mm I.D. X 5.5 mm O.D. Center positive
Fuse	2.5 Amp Fast Acting 5 X 20 mm
Dimensions	3.385" Width X 3.485" Height X 1.9" Depth
Data Type	MIDI 31.5 Khz
Midi input	input 1 (rear), input 2 (front) 5 pin female DIN
Midi output	output 1 (rear) 5 pin female DIN, 20 ma output max
Memory buffer size	112 bytes (37 - 3 byte messages or 112 - 1 byte messages)
Memory Storage Cycles	10,000 times

SV 01.12 MR1